

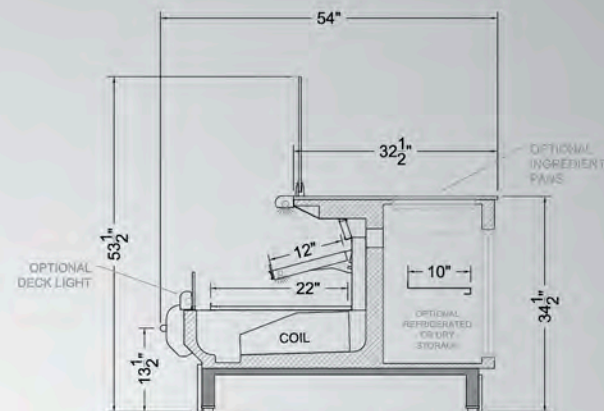

The CVT-WC is a work-counter display and prep combination case with a profile to match the CVT-D merchandiser, allowing for a seamless transition from service dome to prep counter in a CVT line-up. Perfect as a cake decorating station, but also suitable as a sandwich/salad/pizza creation counter, or even as a check-stand, the versatile CVT-WC can find a home in multiple formats.



SECTION VIEW - CVT-WC

Standard Features:

Architecture:

- All welded rigid frame
- CFC-free foam injected seamless basin
- NSF leveler legs

Mechanical:

- High efficiency refrigeration system w/copper tube coils
- Energy efficient fans
- 1 1/2" drains w/traps
- Thermometers
- Ready for remote refrigeration system with:
 - Expansion valves - specify refrigerant
 - Temperature sensors - specify
 - Liquid line hand valve
- Duplex convenience outlet - 20 amp

Interior:

- Work Counter:
 - NSF tempered glass food shield
 - Stainless steel work counter
- Self-Service Base
 - Black interior
 - Removable base display deck with product stop
 - Canopy lighting
 - Metal T-5 lighted shelves - consult drawings
- Open dry rear storage w/black interior

Exterior:

- Standard color finish
- Architectural aluminum nose extrusion
- Tempered glass air dam
- Stainless steel exterior case back w/black kickplate

Options:

- Endpanels:
 - Glass view, shared, or solid end panels
 - Mirror polish or brushed stainless steel end panel interior
- Consult factory on alternative case controls
- Thermostat w/defrost control & suction line solenoid
- Liquid-suction heat exchanger
- Specify for use with secondary coolant systems
- GFCI duplex outlets, CATV communication port, or other
- LED lighting - specify location(s)
- Interior stainless steel finish
- Front deck light - self service base
- Exterior stainless steel, premium color, or laminate finish
- Cart bumper - specify size
- Flip up rear work ledges (poly or stainless steel)
- Stainless, solid surface, or stone counter
- Doors for open dry rear storage compartment
- Rear refrigerated storage - clear or solid insulated doors
- Refrigerated rail for ingredient pans - available only w/ref. storage
- Food shield options - shelves, bins, scale stands, etc.
- Miters, alternative heights/lengths/options - consult factory

Self-Contained Options: (may reduce rear storage)

- Condensing unit
- Electric condensate dissipator
- Digital temperature and defrost controls

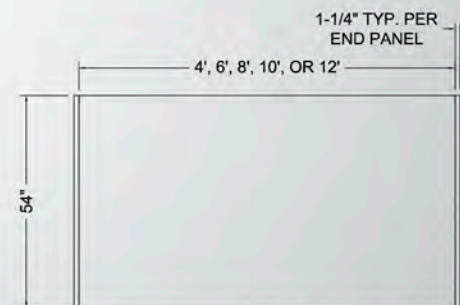

PLAN VIEW