

PLAN MECHANICAL VIEW

08.0-BCX-SS-R

POTOMAC

QTY	DESCRIPTION	PART NUMBER	VOLTAGE	PHASE	AMPS	TOTAL AMPS
8	45" LED 3500K, FROSTED, 24V	LG-FX-XXX-X	115V	1	0.09	0.72
4	EVAPORATOR FAN	RF-FA-XXXX	115V	1	0.17	0.68

CIRCUIT#1 (LIGHTS) TOTAL AMPS: 0.72 VOLTAGE: 115/1/60 CONNECTION: HARDWIRED
 CIRCUIT#2 (FANS) TOTAL AMPS: 0.68 VOLTAGE: 115/1/60 CONNECTION: HARDWIRED
 CIRCUIT#3 (CONV. OUTLET) TOTAL AMPS: 20.00 VOLTAGE: 115/1/60 CONNECTION: HARDWIRED
 MODEL: BCX-SS APPLICATION: BAKERY / PASTRY BTUH: 8000 EVAP TEMP: 22°F

DEFROST: TIME-OFF, 4/30MIN, 47° TEMP TERMINATION
 SHIPPING DIMENSIONS: 108" X 48" X 60"
 WEIGHT: 1220 LBS
 PACKOUT VOLUME: 26.66 CUBIC FT.
 INTERNAL VOLUME: 33.94 CUBIC FT.

CONFORMS TO UL STD 471.
 CONFORMS TO NSF STD 7.
 CERTIFIED TO CAN/CSA STD C22.2 NO. 120.

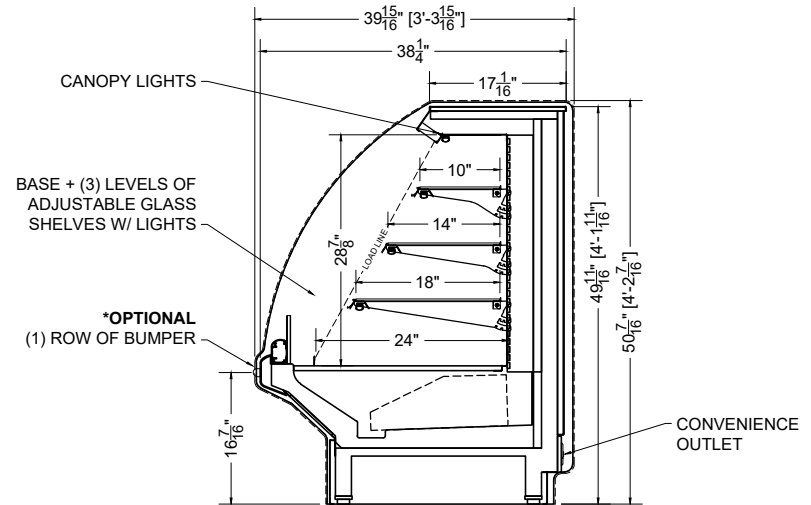

SECTION VIEW

PROJ SPECIFICATION SHEET

Des 08.0-BCX-SS-R Self-Service Bakery Case

Name AME Dwg# 038550 Rev #07-06/10/24

CONFIDENTIAL DOCUMENT: THIS DRAWING IS CONFIDENTIAL AND THE PROPERTY OF SOUTHERN CASEARTS, INC AND IS NOT TO BE REPRODUCED OR EXCHANGED WITH ANY OTHER PERSON OR COMPANY WITHOUT THE EXPRESS WRITTEN CONSENT OF SOUTHERN CASEARTS, INC.

COPYRIGHT ©2023 SOUTHERN CASEARTS, INC. ALL RIGHTS RESERVED

1/2" = 1'

DRAWING DETAILS SUBJECT TO CHANGE DURING THE ENGINEERING PROCESS



SOUTHERN CaseArts