



**Birch**  
**Pastry Merchandiser | Ambient**  
**06.2-CMI-PC-A**



southerncasearts.com | 800.552.6283



## OVERVIEW

The **Birch Pastry Merchandiser** from **Southern CaseArts** provides the ultimate in ambient bakery display. With 5 adjustable wire shelves complete with LED lighting, your customers can't help but be drawn to the bagels, donuts, muffins and other bakery items. The **Birch** features two sets of sliding glass doors which provide maximum visibility and easy access to products on display. The built in cut outs for tissue and bags keep the area neat and tidy while providing added convenience for customers.

### STANDARD FEATURES

- **Nominal Length:** 6.2'
- **Shelves:** 5 Adjustable wire shelves with LED lights
- Sliding glass service doors
- Built in tissue and bag dispenser cutouts
- Unit on casters for easy mobility
- **Exterior:** Black powder coat

### PRODUCT CATEGORIES



Bakery

#### 06.2-CMI-PC-A | Birch Pastry Merchandiser

QTY	DESCRIPTION	PART NUMBER	VOLTAGE	PHASE	AMPS	TOTAL AMPS
10	34" LED 3500K, FROSTED, 24V	LG-FX-XXX-X	115V	1	0.07	0.70
2	VENT FAN	AFXXX	115V	1	0.24	0.48

CIRCUIT#1 (LIGHTS)    **TOTAL AMPS:** 0.70    **VOLTAGE:** 115/1/60    **CONNECTION:** HARDWIRED  
 CIRCUIT#2 (FANS)    **TOTAL AMPS:** 0.48    **VOLTAGE:** 115/1/60    **CONNECTION:** HARDWIRED  
 MODEL: CMI-PC    **APPLICATION:** AMBIENT    **BTUH:** 0    **EVAP TEMP:** N/A  
 DEFROST: N/A  
**SHIPPING DIMENSIONS:** 88" X 48" X 69"  
**WEIGHT:** 900 LBS

**INTERNAL VOLUME:** 30.09 CUBIC FT.



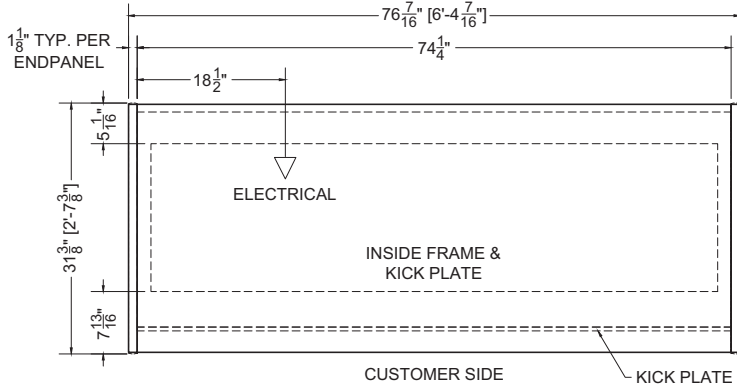

Plan Mechanical View

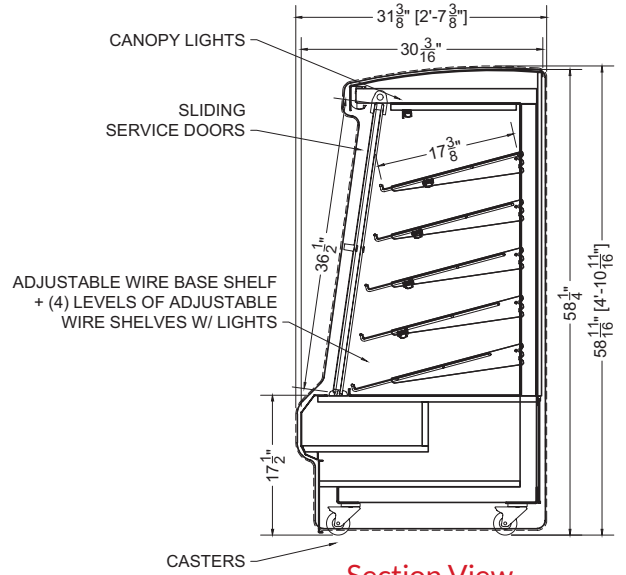

Section View

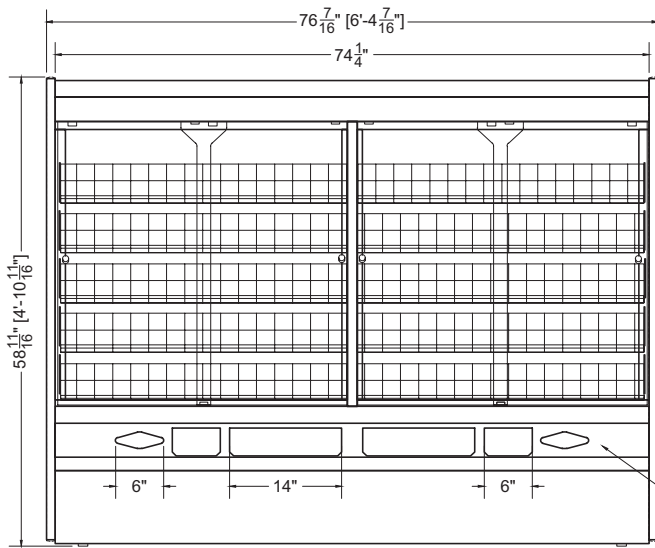

Front View



CONFORMS TO UL STD 65.  
CONFORMS TO NSF STD 2.

For more information on the Birch Pastry/Bakery Merchandiser, contact one of our Southern CaseArts representatives or check out our website to learn more about all of the products offered by Southern CaseArts.