

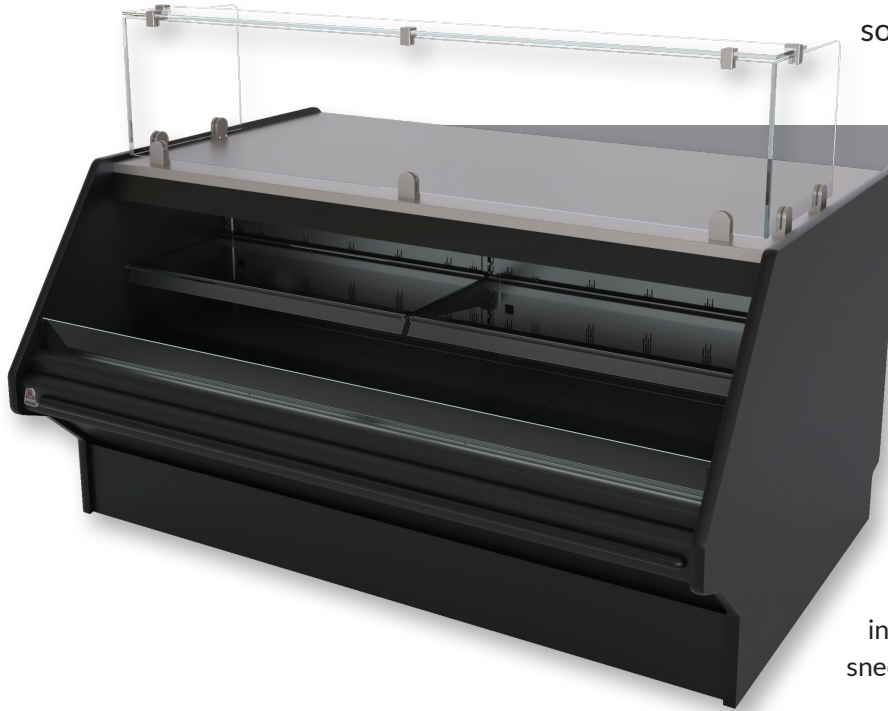

**Mulberry**  
**Bakery Prep & Display Merchandiser | Cold**  
**BCX-BYWC-R**



southerncasearts.com | 800.552.6283



**OVERVIEW**



The **Mulberry Bakery Prep & Display Case** from **Southern CaseArts** is a versatile addition to your bakery area. Available in three lengths, this case provides ample prep & storage space while also providing an appealing merchandise area to showcase everything from meats, cheese, sandwiches, prepared foods, bakery and beverages. The energy efficient **Mulberry** features LED canopy lighting, an adjustable shelf with built in lighting and an attractive tempered glass sneeze guard with top shelf and side returns.

**STANDARD FEATURES**

- **Nominal Length:** 4.0', 6.0' & 8.0'
- **Interior Lighting:** 3500K LED Lights
- Remote
- **Exterior:** Black powder coat

**PRODUCT CATEGORIES**



Meat



Deli



Cheese/  
Dairy



Snacks/  
Sandwiches



Bakery



Beverages



Prepared  
Food

**04.0-BCX-BYWC-R | Mulberry Bakery Prep & Display Merchandiser**

QTY	DESCRIPTION	PART NUMBER	VOLTAGE	PHASE	AMPS	TOTAL AMPS
3	45" LED 3500K, FROSTED, 24V	LG-FX-XXX-X	115V	1	0.09	0.27
2	EVAPORATOR FAN	RF-FA-XXXX	115V	1	0.17	0.34

CIRCUIT#1 (LIGHTS) **TOTAL AMPS:** 0.27 **VOLTAGE:** 115/1/60 **CONNECTION:** HARDWIRED  
 CIRCUIT#2 (FANS) **TOTAL AMPS:** 0.34 **VOLTAGE:** 115/1/60 **CONNECTION:** HARDWIRED  
**MODEL:** BCX-BYWC **APPLICATION:** Bakery/Pastry **BTUH:** 2000 **EVAP TEMP:** 22°F  
**DEFROST:** TIME-OFF, 4/30MIN, 47° TEMP TERMINATION  
 \* OPTIONAL COMPONENT LOAD INCLUDED



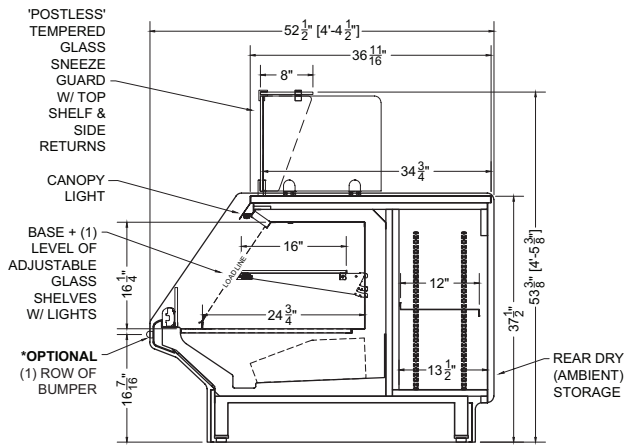

Section View

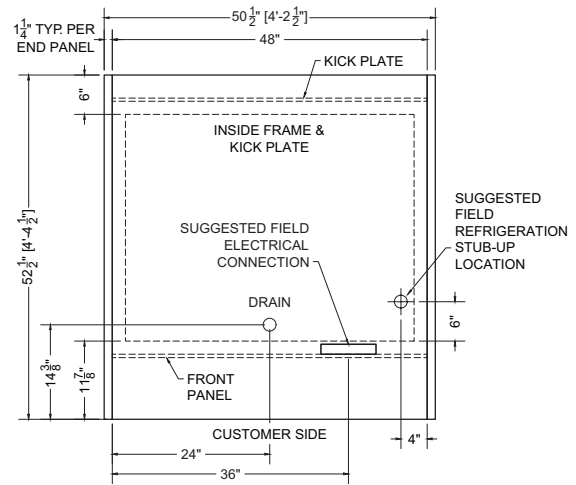

Plan Mechanical View

06.0-BCX-BYWC-R | Mulberry Bakery Prep & Display Merchandiser

QTY	DESCRIPTION	PART NUMBER	VOLTAGE	PHASE	AMPS	TOTAL AMPS
6	34" LED 3500K, FROSTED, 24V	LG-FX-XXX-X	115V	1	0.07	0.42
3	EVAPORATOR FAN	RF-FA-XXXX	115V	1	0.17	0.51

CIRCUIT#1 (LIGHTS) TOTAL AMPS: 0.42 VOLTAGE: 115/1/60 CONNECTION: HARDWIRED  
 CIRCUIT#2 (FANS) TOTAL AMPS: 0.51 VOLTAGE: 115/1/60 CONNECTION: HARDWIRED  
 MODEL: BCX-BYWC APPLICATION: Bakery/Pastry BTUH: 3000 EVAP TEMP: 22°F  
 DEFROST: TIME-OFF, 4/30MIN, 47° TEMP TERMINATION  
 \* OPTIONAL COMPONENT LOAD INCLUDED

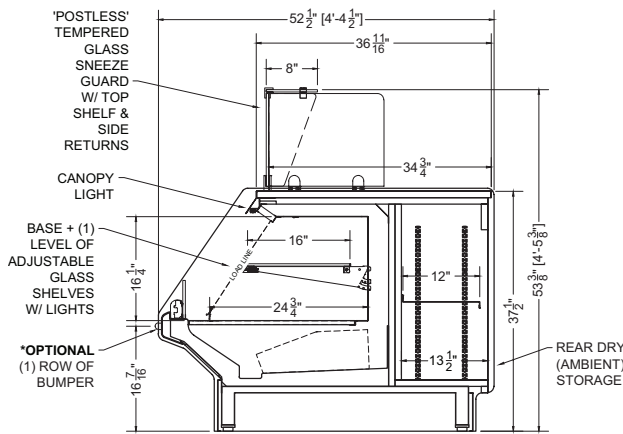

Section View

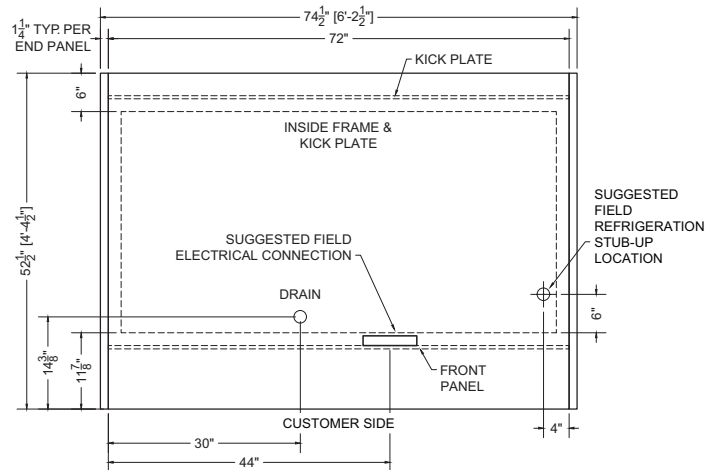

Plan Mechanical View



08.0-BCX-BYWC-R | Mulberry Bakery Prep & Display Merchandiser

QTY	DESCRIPTION	PART NUMBER	VOLTAGE	PHASE	AMPS	TOTAL AMPS
6	45" LED 3500K, FROSTED, 24V	LG-FX-XXX-X	115V	1	0.09	0.54
4	EVAPORATOR FAN	RF-FA-XXXX	115V	1	0.17	0.68

CIRCUIT#1 (LIGHTS) **TOTAL AMPS: 0.54** **VOLTAGE: 115/1/60** **CONNECTION: HARDWIRED**  
 CIRCUIT#2 (FANS) **TOTAL AMPS: 0.68** **VOLTAGE: 115/1/60** **CONNECTION: HARDWIRED**  
**MODEL: BCX-BYWC APPLICATION: Bakery/Pastry BTUH: 4000** **EVAP TEMP: 22°F**  
**DEFROST: TIME-OFF, 4/30MIN, 47° TEMP TERMINATION**  
 \* OPTIONAL COMPONENT LOAD INCLUDED

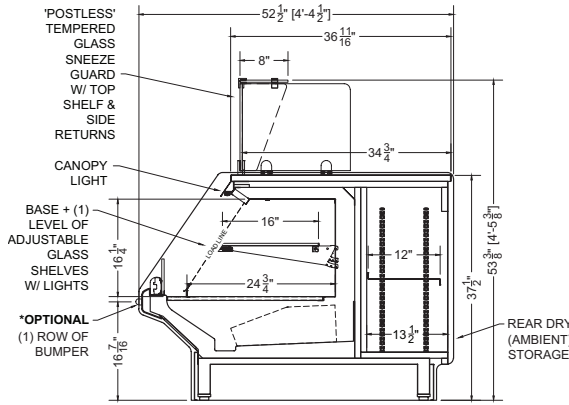

Section View

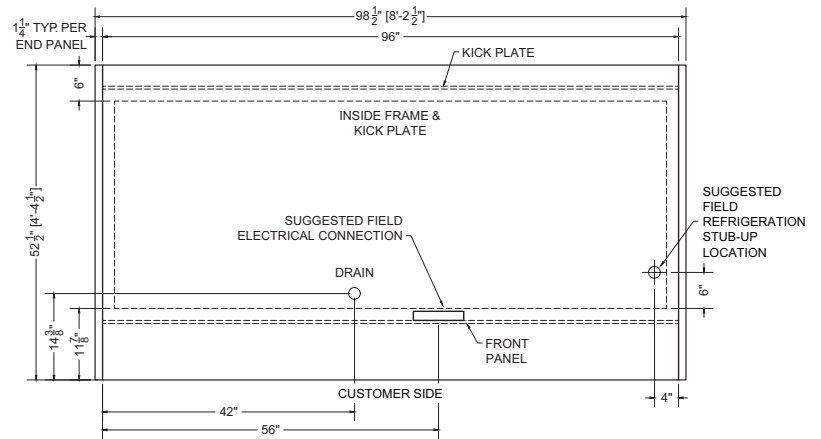

Plan Mechanical View

For more information on this Mulberry Bakery & Prep Display Merchandiser, contact one of our **Southern CaseArts** representatives or check out our website to learn more about all of the products offered by **Southern CaseArts**.