

PLAN MECHANICAL VIEW

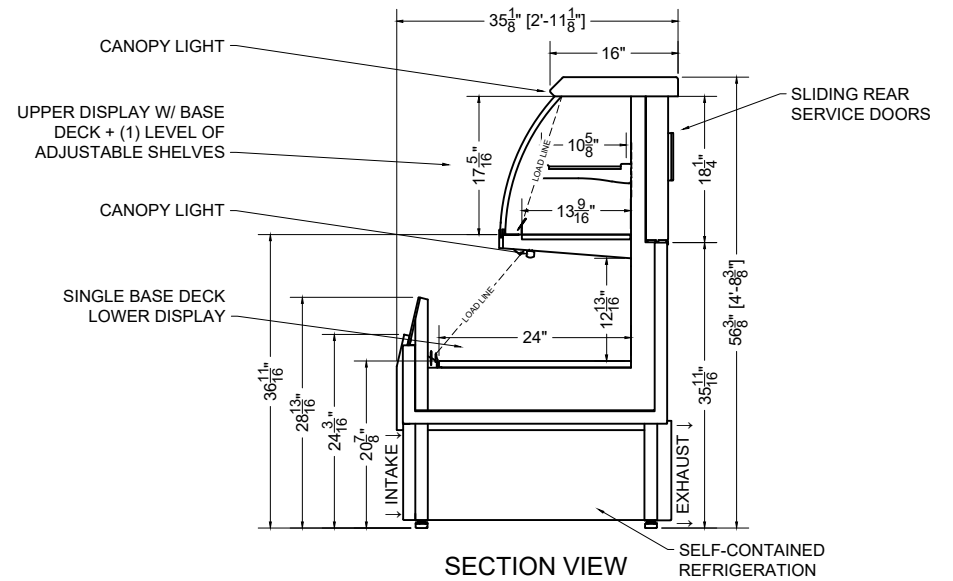

02.3-CHS-56AN-S (SELF-CONTAINED)

COTTONWOOD

QTY	DESCRIPTION	PART NUMBER	VOLTAGE	PHASE	AMPS	TOTAL AMPS
2	24" LED 4000K 24V	LG-FX-XXX-X	115V	1	0.25	0.50
2	EVAPORATOR FAN	AFXXX	115V	1	0.08	0.16
1	COMPRESSOR	---	115V	1	5.95	5.95
1	CONDENSER COIL FAN MOTOR	---	115V	1	0.20	0.20
1	EVAP PAN	---	115V	1	3.48	3.48

CIRCUIT#1 TOTAL AMPS: 10.29 VOLTAGE: 115/1/60 CONNECTION: 5-15P
 MODEL: CHS-56AN APPLICATION: DELI BTUH: 3849 EVAP TEMP: 14°F
 DEFROST: TIME-OFF, 4/45MIN, 50° TEMP TERMINATION

* R290 (PROPANE) REFRIGERATION AVAILABLE

TOP PACKOUT VOLUME: 3.22 CUBIC FT.
 BOTTOM PACKOUT VOLUME: 4.26 CUBIC FT.
 TOP INTERNAL VOLUME: 3.82 CUBIC FT.
 BOTTOM INTERNAL VOLUME: 5.46 CUBIC FT.

PROJ SPECIFICATION SHEET

Des 02.3-CHS-56AN-S Spot Merchandiser (S/C)

Name AME Dwg# 038497 Rev #01- 05/30/24

CONFIDENTIAL DOCUMENT: THIS DRAWING IS CONFIDENTIAL AND THE PROPERTY OF SOUTHERN CASEARTS, INC AND IS NOT TO BE REPRODUCED OR EXCHANGED WITH ANY OTHER PERSON OR COMPANY WITHOUT THE EXPRESS WRITTEN CONSENT OF SOUTHERN CASEARTS, INC.

COPYRIGHT ©2024 SOUTHERN CASEARTS, INC. ALL RIGHTS RESERVED

1/2" = 1"

DRAWING DETAILS SUBJECT TO CHANGE DURING THE ENGINEERING PROCESS



SOUTHERN CaseArts