

PLAN MECHANICAL VIEW

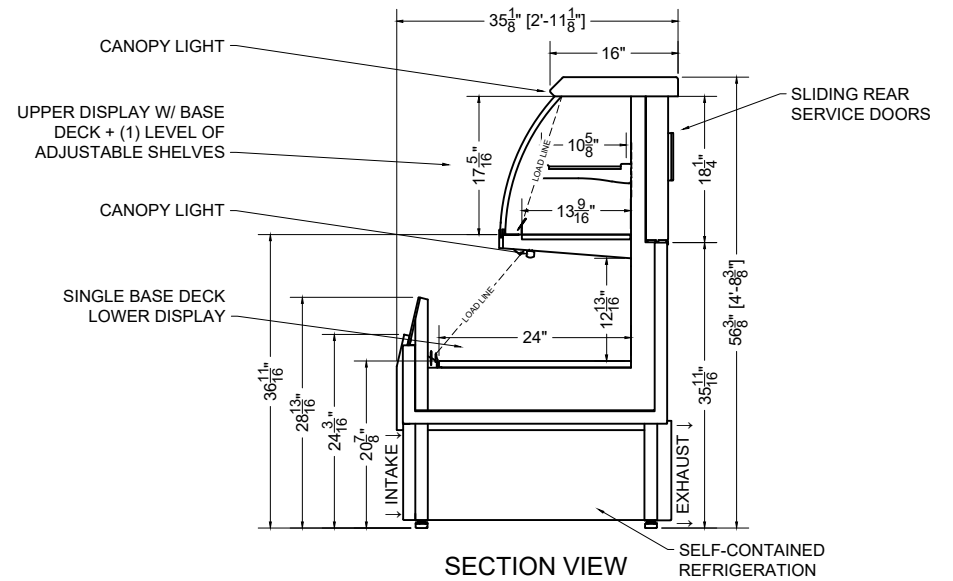

SECTION VIEW

04.1-CHS-56AN-S (SELF-CONTAINED)

COTTONWOOD

QTY	DESCRIPTION	PART NUMBER	VOLTAGE	PHASE	AMPS	TOTAL AMPS
2	45° LED 4000K 24V	LG-FX-XXX-X	115V	1	0.50	1.00
3	EVAPORATOR FAN	AFXXX	115V	1	0.08	0.24
1	COMPRESSOR	---	115V	1	6.96	6.96
2	CONDENSER COIL FAN MOTOR	---	115V	1	0.20	0.40
1	EVAP PAN	---	115V	1	3.48	3.48

CIRCUIT#1 TOTAL AMPS: 12.08 VOLTAGE: 115/1/60 CONNECTION: 5-20P  
 MODEL: CHS-56AN APPLICATION: DELI BTUH: 5074 EVAP TEMP: 14°F  
 DEFROST: TIME-OFF, 4/45MIN, 50° TEMP TERMINATION

\* R290 (PROPANE) REFRIGERATION AVAILABLE

TOP PACKOUT VOLUME: 5.59 CUBIC FT.  
 BOTTOM PACKOUT VOLUME: 7.40 CUBIC FT.  
 TOP INTERNAL VOLUME: 6.63 CUBIC FT.  
 BOTTOM INTERNAL VOLUME: 9.48 CUBIC FT.

