

PLAN MECHANICAL VIEW

04.1-SCS-47ASBL-S (SELF-CONTAINED)

HEMLOCK

QTY	DESCRIPTION	PART NUMBER	VOLTAGE	PHASE	AMPS	TOTAL AMPS
1	45° LED 2700K, 24V	LG-FX-XXX-X	115V	1	0.50	0.50
1	EVAPORATOR FAN	AFXXX	115V	1	0.20	0.20
1	AIR SWEEP FAN	AFXXX	115V	1	0.08	0.08
1	COMPRESSOR	---	115V	1	2.84	2.84
1	CONDENSER COIL FAN MOTOR	---	115V	1	0.20	0.20
1	EVAP PAN	---	115V	1	3.48	3.48
1	GLASS HEATER	---	115V	1	2.17	2.17

CIRCUIT#1 TOTAL AMPS: 9.47 VOLTAGE: 115/1/60 CONNECTION: 5-15P  
 MODEL: SCS-47ASBL APPLICATION: FRESH MEAT BTUH: 2907 EVAP TEMP: 14°F  
 DEFROST: TIME-OFF, 4/45MIN, 50° TEMP TERMINATION  
 \* R290 (PROPANE) REFRIGERATION AVAILABLE

PACKOUT VOLUME: 6.79 CUBIC FT.  
 INTERNAL VOLUME: 19.03 CUBIC FT.

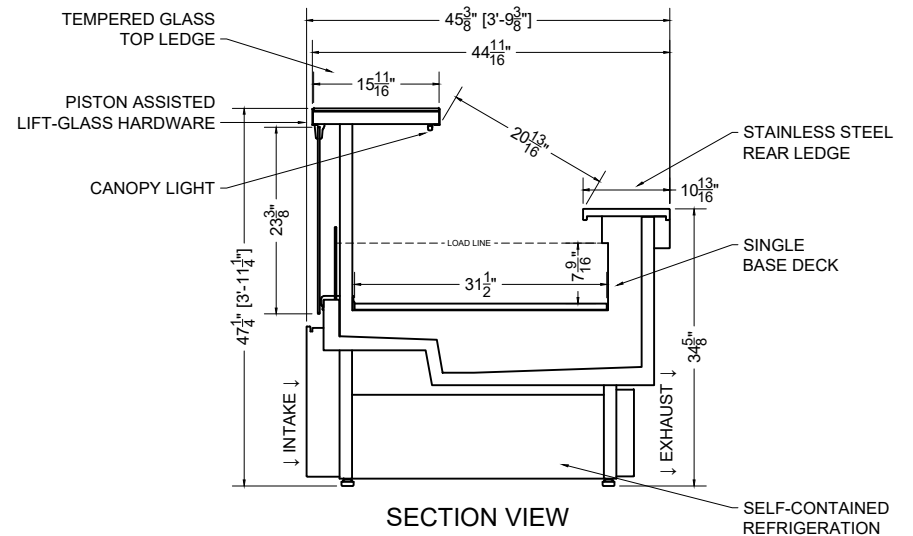

SECTION VIEW

