

PLAN MECHANICAL VIEW

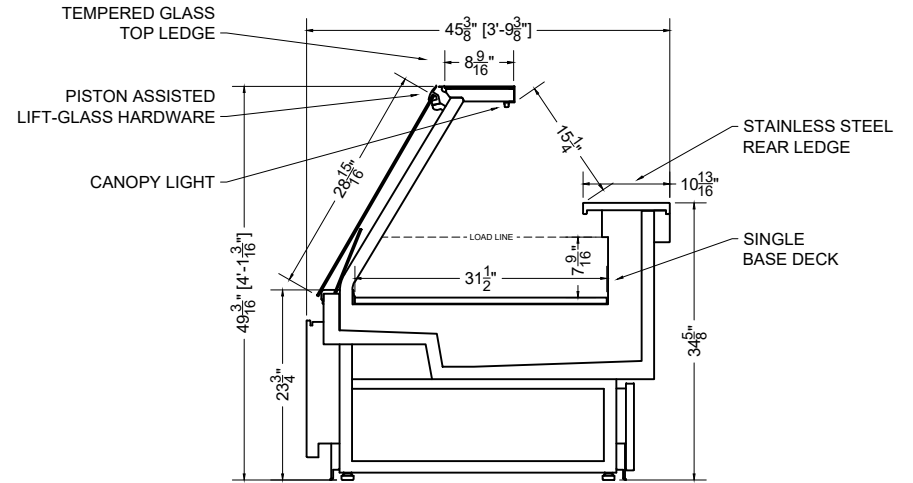

SECTION VIEW

04.1-SCS-49ASIF-R

OZARK

QTY	DESCRIPTION	PART NUMBER	VOLTAGE	PHASE	AMPS	TOTAL AMPS
1	45" LED 2700K 24V	LG-FX-XXX-X	115V	1	0.50	0.50
1	EVAPORATOR FAN	AFXXX	115V	1	0.20	0.20
1	AIR SWEEP FAN	AFXXX	115V	1	0.08	0.08

CIRCUIT#1 (LIGHTS)	TOTAL AMPS:0.50	VOLTAGE:115/1/60	CONNECTION:HARDWIRED
CIRCUIT#2 (FANS)	TOTAL AMPS:0.20	VOLTAGE:115/1/60	CONNECTION:HARDWIRED
CIRCUIT#3 (ANTI-COND.)	TOTAL AMPS:0.08	VOLTAGE:115/1/60	CONNECTION:HARDWIRED
MODEL:SCS-49ASIF	APPLICATION:FRESH MEAT	BTUH:1919	EVAP TEMP: 14°F
DEFROST: TIME-OFF, 4/45MIN, 50° TEMP TERMINATION			

PACKOUT VOLUME: 6.48 CUBIC FT.  
INTERNAL VOLUME: 17.43 CUBIC FT.

PROJ SPECIFICATION SHEET

DESIGN 04.1-SCS-49ASIF-R Inclined Service Over Counter

NAME AME DWG# 038280 REV #IR- 04/12/24

CONFIDENTIAL DOCUMENT: THIS DRAWING IS CONFIDENTIAL AND THE PROPERTY OF SOUTHERN CASEARTS, INC AND IS NOT TO BE REPRODUCED OR EXCHANGED WITH ANY OTHER PERSON OR COMPANY WITHOUT THE EXPRESS WRITTEN CONSENT OF SOUTHERN CASEARTS, INC.

COPYRIGHT ©2024 SOUTHERN CASEARTS, INC. ALL RIGHTS RESERVED

1/2" = 1'

DRAWING DETAILS SUBJECT TO CHANGE DURING THE ENGINEERING PROCESS



SOUTHERN CaseArts