

PLAN MECHANICAL VIEW

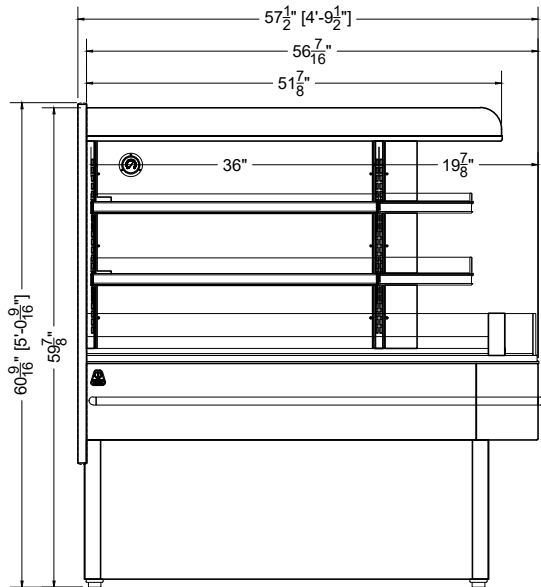

SIDE VIEW

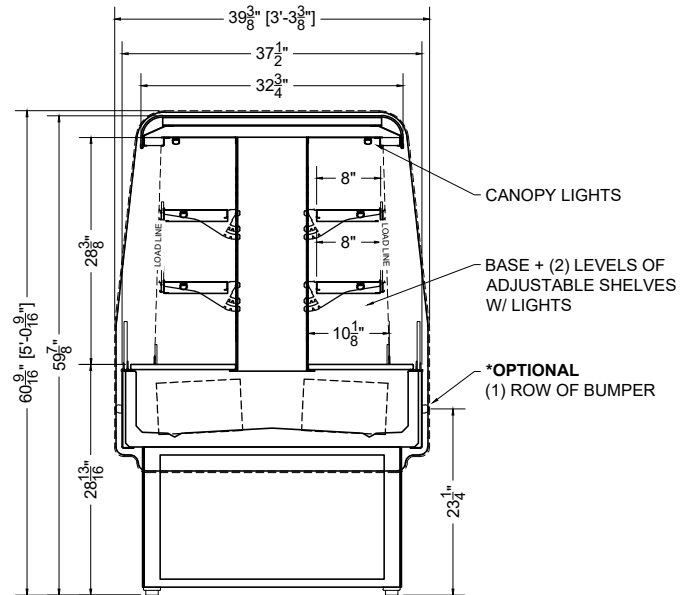

SECTION VIEW

04.6-MDI-3N1P-R = 3' CENTER + (1) PARTIAL-RADIUS END

PLACID

QTY	DESCRIPTION	PART NUMBER	VOLTAGE	PHASE	AMPS	TOTAL AMPS
2	12" LED 3500K, FROSTED, 24V	LG-FX-XXX-X	115V	1	0.02	0.04
2	18" LED 3500K, FROSTED, 24V	LG-FX-XXX-X	115V	1	0.03	0.06
6	34" LED 3500K, FROSTED, 24V	LG-FX-XXX-X	115V	1	0.07	0.42
6	EVAPORATOR FAN	AFXXX	115V	1	0.24	1.44

CIRCUIT#1 (LIGHTS) TOTAL AMPS:0.52 VOLTAGE:115/1/60 CONNECTION:HARDWIRED  
 CIRCUIT#2 (FANS) TOTAL AMPS:1.44 VOLTAGE:115/1/60 CONNECTION:HARDWIRED  
 MODEL:MDI-3N APPLICATION:DELI BTUH:7200 EVAP TEMP: 20°F  
 DEFROST:TIME-OFF, 4/40MIN, 47° TEMP TERMINATION  
 SHIPPING DIMENSIONS: 72" X 48" X 72"  
 WEIGHT: 750 LBS

PACKOUT VOLUME: 17.77 CUBIC FT.  
 INTERNAL VOLUME: 24.01 CUBIC FT.

CONFORMS TO UL STD 471.  
 CONFORMS TO NSF STD 7.  
 CERTIFIED TO CAN/CSA STD C22.2 NO. 120.

