

PLAN MECHANICAL VIEW

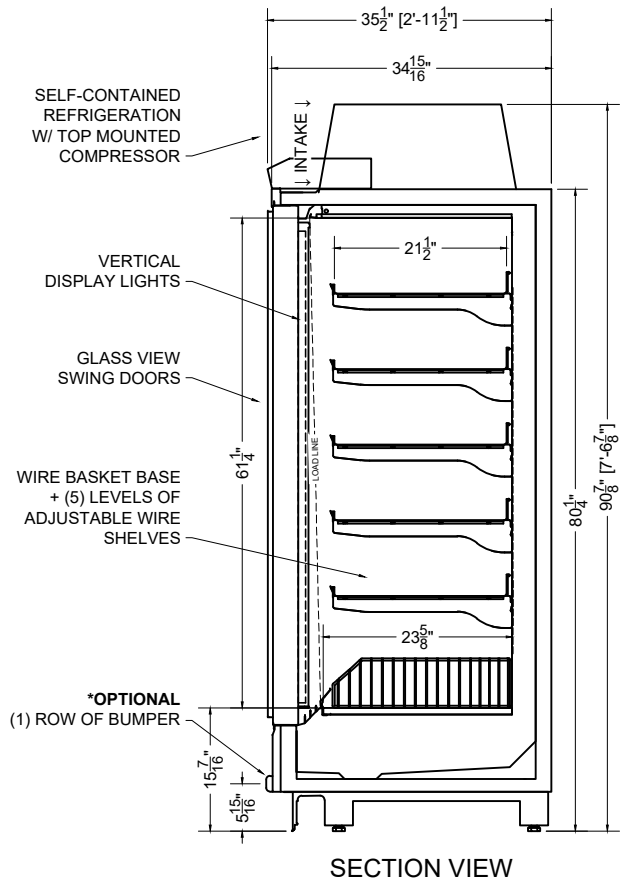

SECTION VIEW

05.1-MDD-81TNF-S = SELF-CONTAINED, 2 DOOR

DIABLO

QTY	DESCRIPTION	PART NUMBER	VOLTAGE	PHASE	AMPS	TOTAL AMPS
4	59" LED 4000K 24V	LG-FX-XXX-X	208-230V	1	0.67	2.67
2	EVAPORATOR FAN	AFXXX	208-230V	1	0.10	0.20
1	DOOR HEATERS	---	208-230V	1	1.14	1.14
1	DEFROST HEATERS	---	208-230V	1	9.09	9.09
1	COMPRESSOR	---	208-230V	1	6.17	6.17
3	CONDENSER COIL FAN MOTOR	---	208-230V	1	0.10	0.30
1	CONDENSATE PUMP	---	208-230V	1	0.25	0.25
1	EVAP PAN	---	208-230V	1	1.82	1.82

*NOT INCLUDED IN TOTAL

CIRCUIT#1 TOTAL AMPS: 15.46" VOLTAGE: 208-230/1/60 CONNECTION: 6-30P
 * NOT ALL ELECTRICAL COMPONENTS RUN CONCURRENTLY (COMPRESSOR WILL NOT RUN DURING DEFROST)
 MODEL: MDD-81TNF APPLICATION: FROZEN BTUH: 3491 EVAP TEMP: -31°F
 DEFROST: TIME-OFF, 4/45MIN, 50° TEMP TERMINATION
 * R290 (PROPANE) REFRIGERATION AVAILABLE

PACKOUT VOLUME: 53.67 CUBIC FT.
 INTERNAL VOLUME: 58.41 CUBIC FT.

