

06.0-FLX-PX02-S (WITH CASTERS, SELF-CONTAINED)

WILLOW

QTY	DESCRIPTION	PART NUMBER	VOLTAGE	PHASE	AMPS	TOTAL AMPS
2	EVAPORATOR FAN	RF-FA-XXXX	115V	1	0.17	0.34
1	CONDENSING UNIT	RF-CU-0383-A	115V	1	12.10	12.10
1	CONDENSATE EVAP PAN / 800W / FULL	EL-EV-XXXX	115V	1	6.67	6.67

CIRCUIT#1

TOTAL AMPS:19.11

VOLTAGE:115/1/60

CONNECTION:L5-30P

PACKOUT VOLUME: 14.43 CUBIC FT.

INTERNAL VOLUME: 18.62 CUBIC FT.

CONFORMS TO UL STD 471.  
CONFORMS TO NSF STD 7.  
CERTIFIED TO CAN/CSA STD  
C22.2 NO. 120.

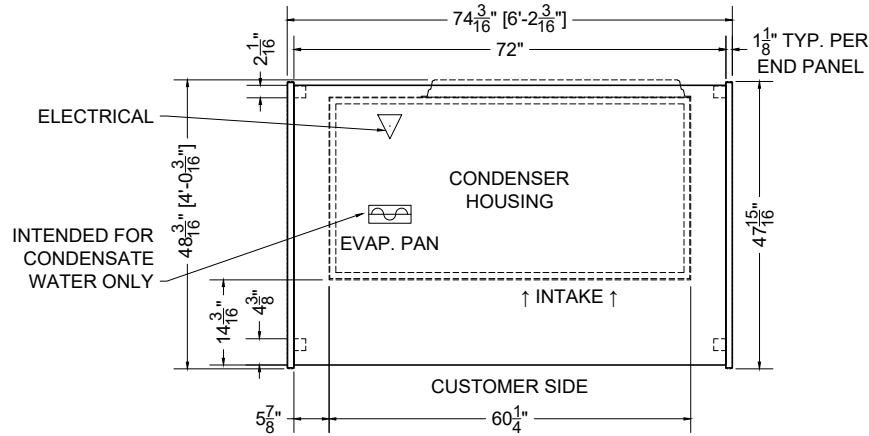

PLAN MECHANICAL VIEW

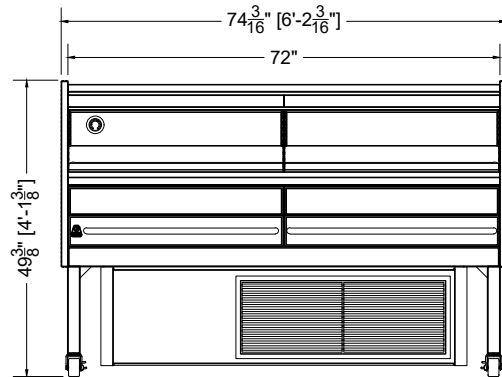

FRONT VIEW

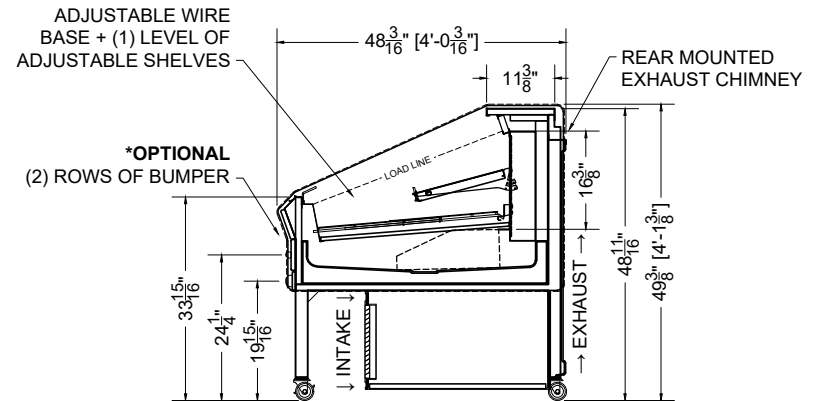

SECTION VIEW

PROJ SPECIFICATION SHEET

Des: 06.0-FLX-PX02-S Mobile Produce Display (W/ CASTERS, S/C)

Name: AME Dwg#: 038557 Rev: #03- 06/14/24

CONFIDENTIAL DOCUMENT: THIS DRAWING IS CONFIDENTIAL AND THE PROPERTY OF SOUTHERN CASEARTS, INC AND IS NOT TO BE REPRODUCED OR EXCHANGED WITH ANY OTHER PERSON OR COMPANY WITHOUT THE EXPRESS WRITTEN CONSENT OF SOUTHERN CASEARTS, INC.

COPYRIGHT ©2024 SOUTHERN CASEARTS, INC. ALL RIGHTS RESERVED

3/8" = 1"

DRAWING DETAILS SUBJECT TO CHANGE DURING THE ENGINEERING PROCESS



SOUTHERN CaseArts