

PLAN MECHANICAL VIEW

06.0-MDC-83HN-R

CIMARRON

QTY	DESCRIPTION	PART NUMBER	VOLTAGE	PHASE	AMPS	TOTAL AMPS
10	34" LED 3500K, FROSTED, 24V	LG-FX-XXX-X	115V	1	0.07	0.70
3	EVAPORATOR FAN	RF-FA-XXXX	115V	1	0.17	0.51

CIRCUIT#1 (LIGHTS) TOTAL AMPS:0.70 VOLTAGE:115/1/60 CONNECTION:HARDWIRED  
 CIRCUIT#2 (FANS) TOTAL AMPS:0.51 VOLTAGE:115/1/60 CONNECTION:HARDWIRED  
 MODEL:MDC-83HN APPLICATION:DELI BTUH:8000 EVAP TEMP: 18°F  
 DEFROST: TIME-OFF, 4/40MIN, 47° TEMP TERMINATION  
 SHIPPING DIMENSIONS: 86" X 48" X 93"  
 WEIGHT: 1200 LBS  
 PACKOUT VOLUME: 36.35 CUBIC FT.  
 INTERNAL VOLUME: 50.18 CUBIC FT.

CONFORMS TO UL STD 471.  
 CONFORMS TO NSF STD 7.  
 CERTIFIED TO CAN/CSA STD C22.2 NO. 120.

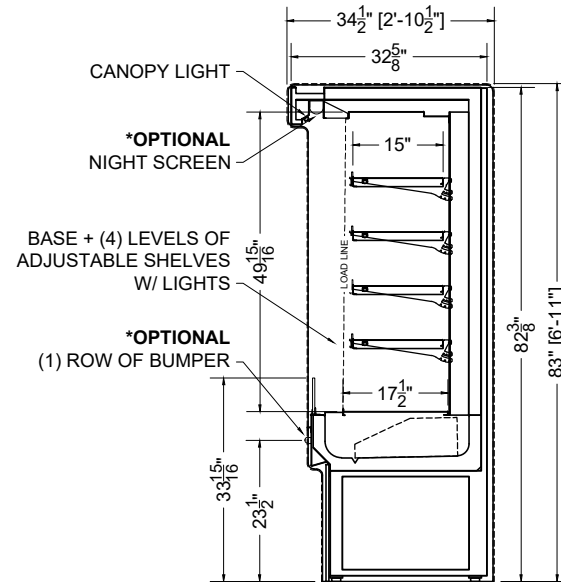

SECTION VIEW

PROJ SPECIFICATION SHEET

Des 06.0-MDC-83HN-R Narrow High Nose Multi-Deck

Name AME Dwg# 037853 Rev #01 - 11/13/23

CONFIDENTIAL DOCUMENT: THIS DRAWING IS CONFIDENTIAL AND THE PROPERTY OF SOUTHERN CASEARTS, INC AND IS NOT TO BE REPRODUCED OR EXCHANGED WITH ANY OTHER PERSON OR COMPANY WITHOUT THE EXPRESS WRITTEN CONSENT OF SOUTHERN CASEARTS, INC.

COPYRIGHT ©2023 SOUTHERN CASEARTS, INC. ALL RIGHTS RESERVED

38" = 1"

DRAWING DETAILS SUBJECT TO CHANGE DURING THE ENGINEERING PROCESS



SOUTHERN CaseArts