

PLAN MECHANICAL VIEW

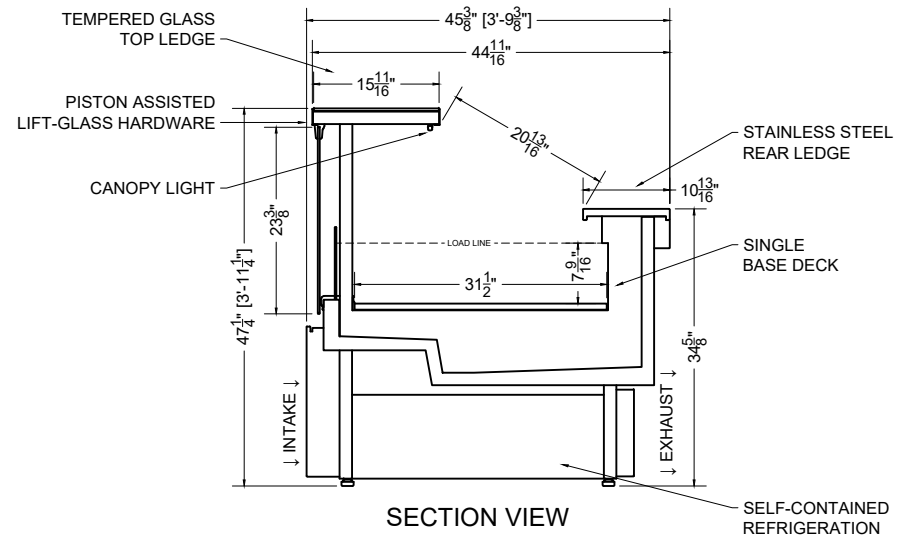

SECTION VIEW

06.2-SCS-47ASBL-S (SELF-CONTAINED)

HEMLOCK

QTY	DESCRIPTION	PART NUMBER	VOLTAGE	PHASE	AMPS	TOTAL AMPS
2	34" LED 2700K, 24V	LG-FX-XXX-X	115V	1	0.38	0.75
2	EVAPORATOR FAN	AFXXX	115V	1	0.20	0.40
2	AIR SWEEP FAN	AFXXX	115V	1	0.08	0.16
1	COMPRESSOR	---	115V	1	4.22	4.22
1	CONDENSER COIL FAN MOTOR	---	115V	1	0.20	0.20
1	EVAP PAN	---	115V	1	6.09	6.09
1	GLASS HEATER	---	115V	1	3.48	3.48

CIRCUIT#1 TOTAL AMPS: 15.30 VOLTAGE: 115/1/60 CONNECTION: 5-20P
 MODEL: SCS-47ASBL APPLICATION: FRESH MEAT BTUH: 3634 EVAP TEMP: 14°F
 DEFROST: TIME-OFF, 4/45MIN, 50° TEMP TERMINATION
 * R290 (PROPANE) REFRIGERATION AVAILABLE
 PACKOUT VOLUME: 10.19 CUBIC FT.
 INTERNAL VOLUME: 28.55 CUBIC FT.

