

08.0-MDC-54HEM-S MULTI-DECK DISPLAY (SELF-CONTAINED)

APPALACHIAN

QTY	DESCRIPTION	PART NUMBER	VOLTAGE	PHASE	AMPS	TOTAL AMPS
6	45" LED 3500K, FROSTED, 24V	LG-FX-XXX-X	115V	1	0.09	0.54
4	EVAPORATOR FAN	RF-FA-XXXX	115V	1	0.17	0.68
1	CONDENSING UNIT	RF-CU-0479-A	115V	1	11.90	11.90
1	CONDENSATE EVAP PAN / 1200W / FULL	EL-EV-XXXX	115V	1	10.00	10.00

CIRCUIT#1 TOTAL AMPS: 23.12 VOLTAGE: 115V/160 CONNECTION: L5-30P
 MODEL: MDC-54HEM APPLICATION: DELI BTUH: 6800 EVAP TEMP: 24°F
 DEFROST: TIME-OFF, 4/40MIN, 47° TEMP TERMINATION
 SHIPPING DIMENSIONS: 108" X 48" X 68"
 WEIGHT: 1365 LBS

PACKOUT VOLUME: 28.96 CUBIC FT.
 INTERNAL VOLUME: 37.10 CUBIC FT.

CONFORMS TO UL STD 471.
 CONFORMS TO NSF STD 7.
 CERTIFIED TO ANCSA STD
 C22.2 NO. 120.

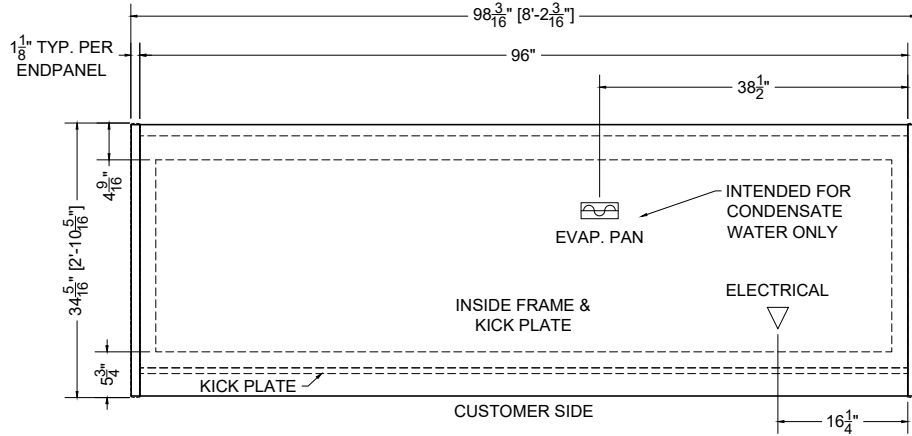

PLAN MECHANICAL VIEW

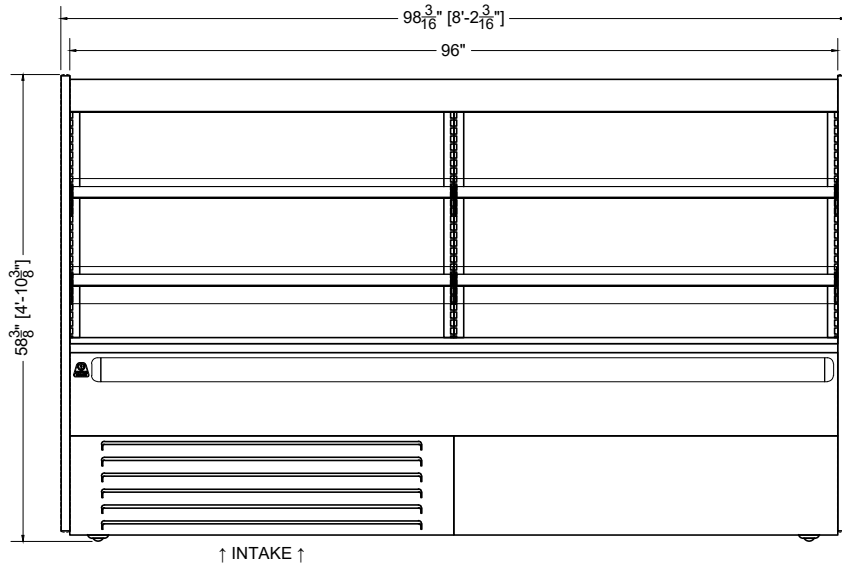

FRONT VIEW

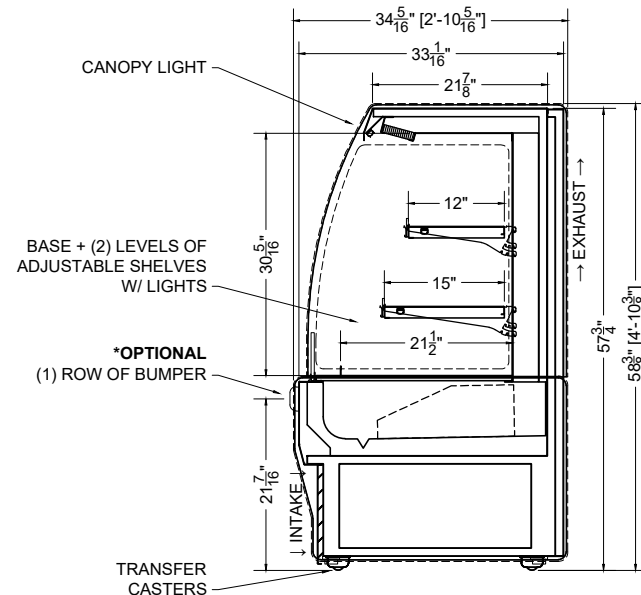

SECTION VIEW

PROJ SPECIFICATION SHEET

Des: 08.0-MDC-54HEM-S Multi-Deck Display (S/C)

Name: AME Dwg#: 038259 Rev: #03- 04/10/24

CONFIDENTIAL DOCUMENT: THIS DRAWING IS CONFIDENTIAL AND THE PROPERTY OF SOUTHERN CASEARTS, INC AND IS NOT TO BE REPRODUCED OR EXCHANGED WITH ANY OTHER PERSON OR COMPANY WITHOUT THE EXPRESS WRITTEN CONSENT OF SOUTHERN CASEARTS, INC.

COPYRIGHT ©2023 SOUTHERN CASEARTS, INC. ALL RIGHTS RESERVED

1/2" = 1"

DRAWING DETAILS SUBJECT TO CHANGE DURING THE ENGINEERING PROCESS



SOUTHERN CaseArts