

PLAN MECHANICAL VIEW

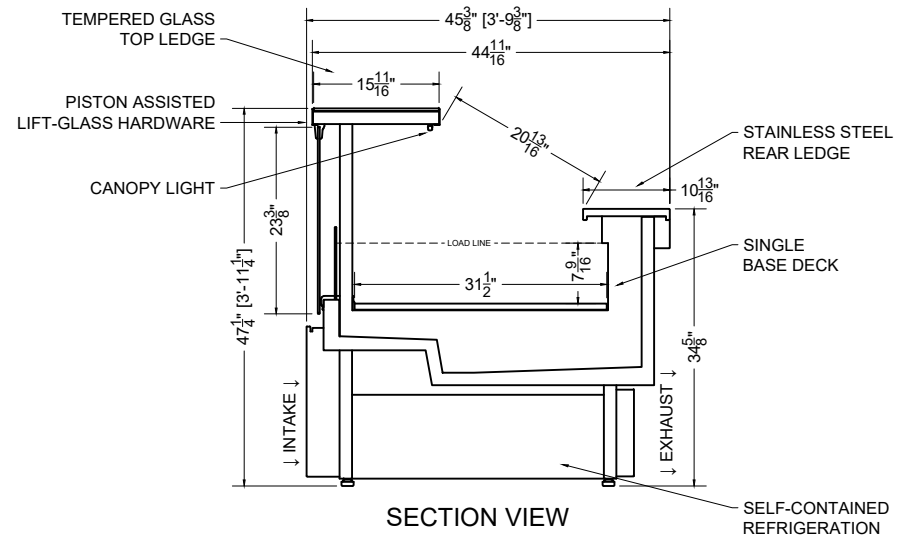

SECTION VIEW

08.2-SCS-47ASBL-S (SELF-CONTAINED)

						HEMLOCK
QTY	DESCRIPTION	PART NUMBER	VOLTAGE	PHASE	AMPS	TOTAL AMPS
2	45" LED 2700K, 24V	LG-FX-XXX-X	115V	1	0.50	1.00
2	EVAPORATOR FAN	AFXXX	115V	1	0.20	0.40
2	AIR SWEEP FAN	AFXXX	115V	1	0.08	0.16
1	COMPRESSOR	--	115V	1	5.95	5.95
2	CONDENSER COIL FAN MOTOR	--	115V	1	0.20	0.40
1	EVAP PAN	--	115V	1	6.09	6.09
1	GLASS HEATER	--	115V	1	5.22	5.22

CIRCUIT#1 TOTAL AMPS: 19.22 VOLTAGE: 115/1/60 CONNECTION: 5-30P
 MODEL: SCS-47ASBL APPLICATION: FRESH MEAT BTUH: 5275 EVAP TEMP: 14°F
 DEFROST: TIME-OFF, 4/45MIN, 50° TEMP TERMINATION
 * R290 (PROPANE) REFRIGERATION AVAILABLE
 PACKOUT VOLUME: 13.59 CUBIC FT.
 INTERNAL VOLUME: 38.06 CUBIC FT.

