

10.0-RIM-3N2-S = 6' CENTER + (2) SQUARED ENDS (SELF-CONTAINED)

SUPERIOR

QTY	DESCRIPTION	PART NUMBER	VOLTAGE	PHASE	AMPS	TOTAL AMPS
2	18" LED 3500K, FROSTED, 24V	LG-FX-XXX-X	115V	1	0.03	0.06
4	23" LED 3500K, FROSTED, 24V	LG-FX-XXX-X	115V	1	0.04	0.16
8	34" LED 3500K, FROSTED, 24V	LG-FX-XXX-X	115V	1	0.07	0.56
4	40" LED 3500K, FROSTED, 24V	LG-FX-XXX-X	115V	1	0.08	0.32
8	EVAPORATOR FAN	RF-FA-XXXX	115V	1	0.17	1.36
2	CONDENSING UNIT	RF-CU-0472-A	208V	1	8.10	16.20
2	CONDENSATE EVAP PAN / 1500W / FULL	EL-EV-XXXX	208V	1	7.21	14.42

CIRCUIT#1 TOTAL AMPS: 17.09 VOLTAGE: 208-230/1/60, 3-WIRE CONNECTION: L14-30P
 CIRCUIT#2 TOTAL AMPS: 15.99 VOLTAGE: 208-230/1/60, 3-WIRE CONNECTION: L14-30P
 SHIPPING DIMENSIONS: 132" X 66" X 69" PACKOUT VOLUME: 40.43 CUBIC FT.
 WEIGHT: 1928 LBS INTERNAL VOLUME: 58.07 CUBIC FT.

CONFORMS TO UL STD 471.
 CONFORMS TO NSF STD 7.
 CERTIFIED TO CAN/CSA STD
 C22.2 NO. 120.

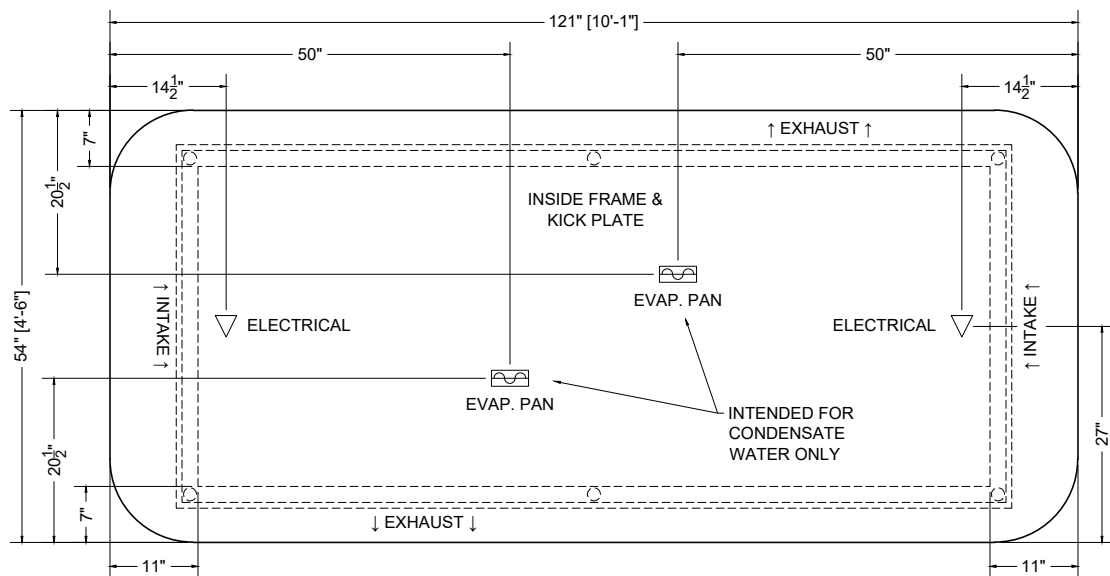

PLAN MECHANICAL VIEW

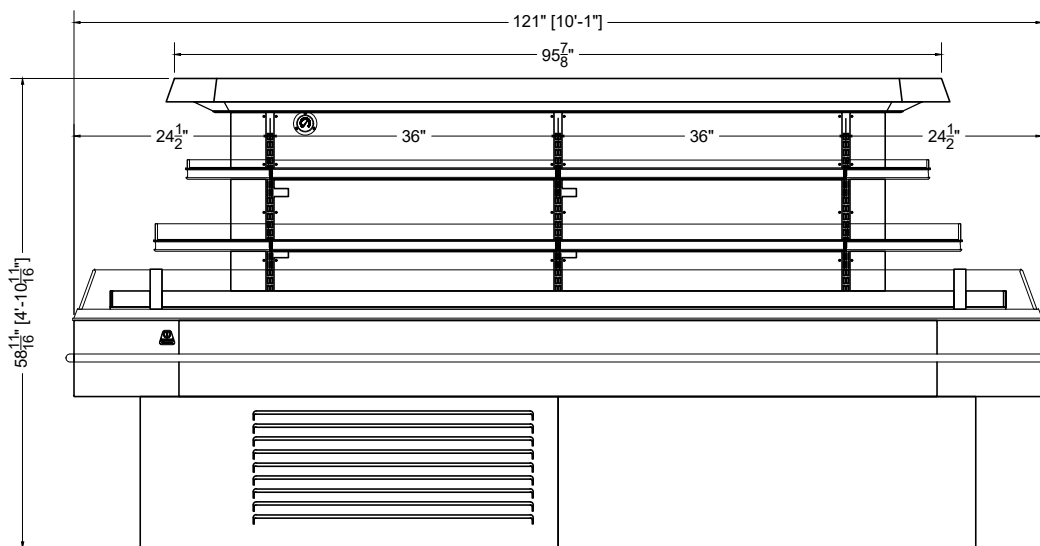

FRONT VIEW

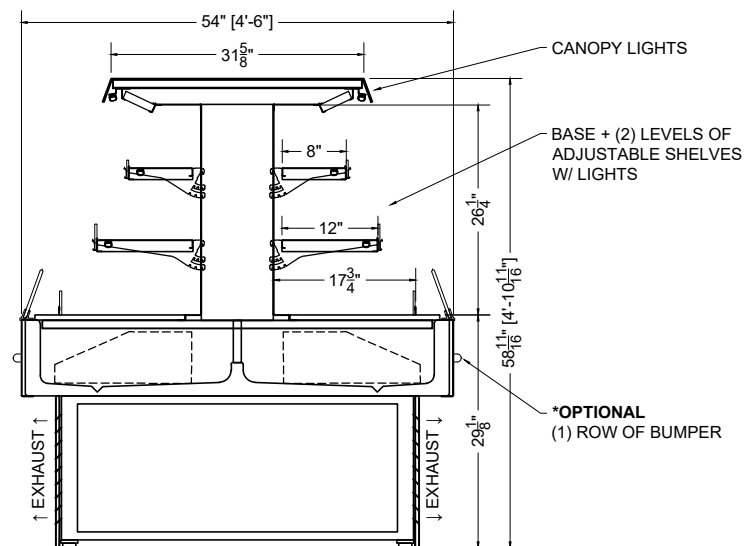

SECTION VIEW

PROJ SPECIFICATION SHEET

Des 10.0-RIM-3N2-S - (2) Squared Ends (S/C)

Name AME Dwg# 037922 Rev #07- 12/11/23

CONFIDENTIAL DOCUMENT: THIS DRAWING IS CONFIDENTIAL AND THE PROPERTY OF SOUTHERN CASEARTS, INC AND IS NOT TO BE REPRODUCED OR EXCHANGED WITH ANY OTHER PERSON OR COMPANY WITHOUT THE EXPRESS WRITTEN CONSENT OF SOUTHERN CASEARTS, INC.

COPYRIGHT ©2023 SOUTHERN CASEARTS, INC. ALL RIGHTS RESERVED

1/2" = 1'

DRAWING DETAILS SUBJECT TO CHANGE DURING THE ENGINEERING PROCESS



SOUTHERN CaseArts