

10.1-FSE-HCI3-H

QTY	DESCRIPTION	PART NUMBER	VOLTAGE	PHASE	AMPS	TOTAL AMPS	L1	L2
18	12" LED 3500K, FROSTED, 24V	LG-FX-XXX-X	115V	1	0.02	0.36	0.36	---
12	29" LED 3500K, FROSTED, 24V	LG-FX-XXX-X	115V	1	0.05	0.60	0.60	---
6	34" LED 3500K, FROSTED, 24V	LG-FX-XXX-X	115V	1	0.07	0.42	0.42	---
8	FOIL HEATER, SHELF, 3"	FS-HT-0588-A	208V	1	2.70	21.60	21.60	21.60
8	FOIL HEATER, CUSTOMER LEFT	FS-HT-0962-A	208V	1	2.02	16.16	16.16	16.16
8	FOIL HEATER, CUSTOMER RIGHT	FS-HT-0963-A	208V	1	2.02	16.16	16.16	16.16
8	FOIL HEATER, RADIUS END	FS-HT-0964-A	208V	1	1.78	14.24	14.24	14.24

CIRCUIT#1 (LOAD CENTER) TOTAL AMPS:(L1 = 69.54 / L2 = 68.16) VOLTAGE:208/1/60, 3-WIRE CONNECTION:HARDWIRED

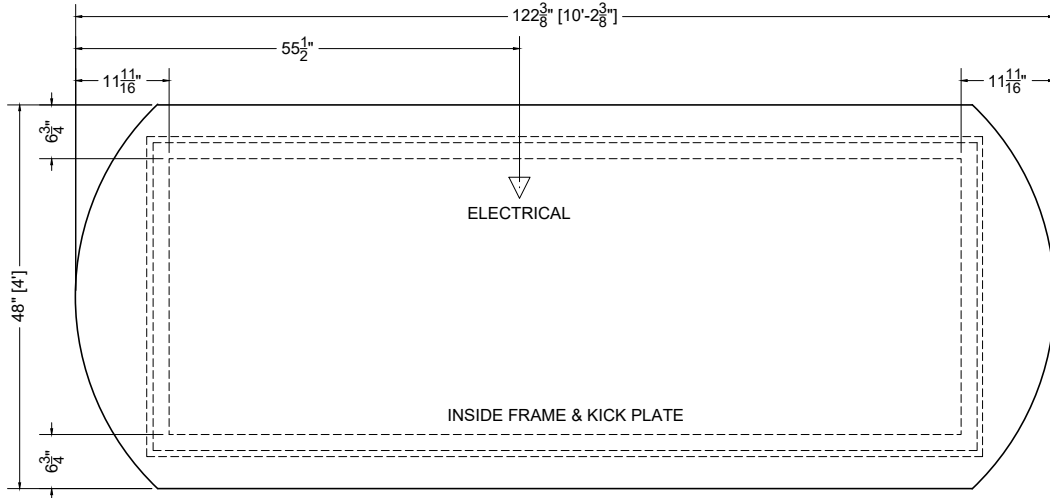

PLAN MECHANICAL VIEW

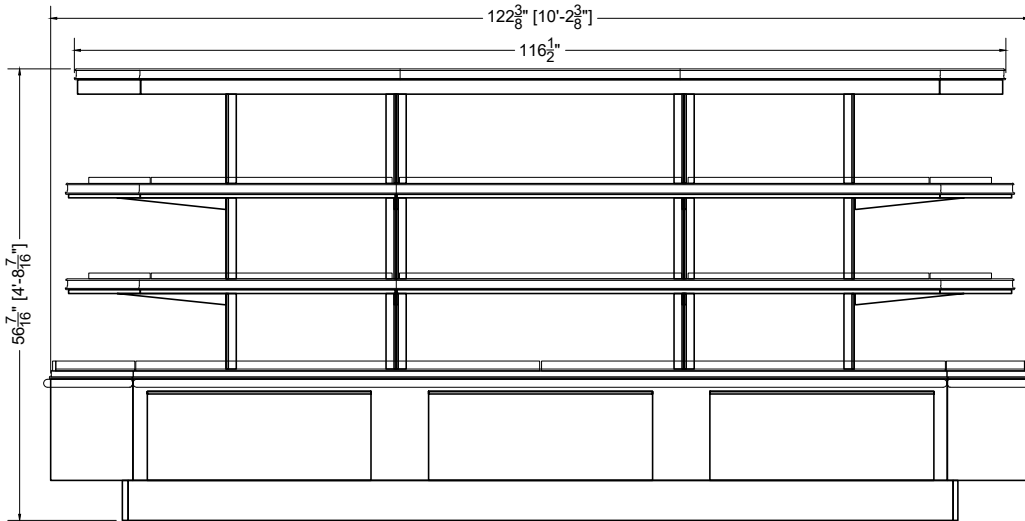

SIDE VIEW

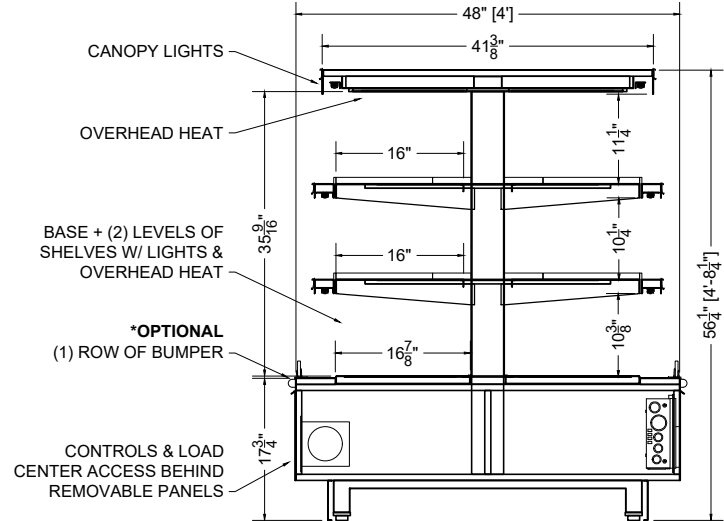

SECTION VIEW

CONFORMS TO UL STD 197.
CONFORMS TO NSF STD 4.
CERTIFIED TO CAN/CSA STD
C22.2 NO. 120.



PROJ SPECIFICATION SHEET

Des 10.1-FSE-HCI3-H Hot Foods Island

Name AME Dwg# 037682 Rev #01 - 08/24/23

CONFIDENTIAL DOCUMENT: THIS DRAWING IS CONFIDENTIAL AND THE PROPERTY OF SOUTHERN CASEARTS, INC AND IS NOT TO BE REPRODUCED OR EXCHANGED WITH ANY OTHER PERSON OR COMPANY WITHOUT THE EXPRESS WRITTEN CONSENT OF SOUTHERN CASEARTS, INC.

COPYRIGHT ©2023 SOUTHERN CASEARTS, INC. ALL RIGHTS RESERVED

1/2" = 1'

DRAWING DETAILS SUBJECT TO CHANGE DURING THE ENGINEERING PROCESS



SOUTHERN CaseArts