

PLAN MECHANICAL VIEW

12.0-MDC-83HN-R

CIMARRON

QTY	DESCRIPTION	PART NUMBER	VOLTAGE	PHASE	AMPS	TOTAL AMPS
15	45° LED 3500K, FROSTED, 24V	LG-FX-XXX-X	115V	1	0.09	1.35
5	EVAPORATOR FAN	RF-FA-XXXX	115V	1	0.17	0.85

CIRCUIT#1 (LIGHTS) TOTAL AMPS: 1.35 VOLTAGE: 115/1/60 CONNECTION: HARDWIRED
 CIRCUIT#2 (FANS) TOTAL AMPS: 0.85 VOLTAGE: 115/1/60 CONNECTION: HARDWIRED
 MODEL: MDC-83HN APPLICATION: DELI BTUH: 16000 EVAP TEMP: 18°F
 DEFROST: TIME-OFF, 4/40MIN, 47° TEMP TERMINATION
 SHIPPING DIMENSIONS: 160" X 48" X 93"
 WEIGHT: 2125 LBS

PACKOUT VOLUME: 72.70 CUBIC FT.
 INTERNAL VOLUME: 100.36 CUBIC FT.

CONFORMS TO UL STD 471.
 CONFORMS TO NSF STD 7.
 CERTIFIED TO CAN/CSA STD C22.2 NO. 120.

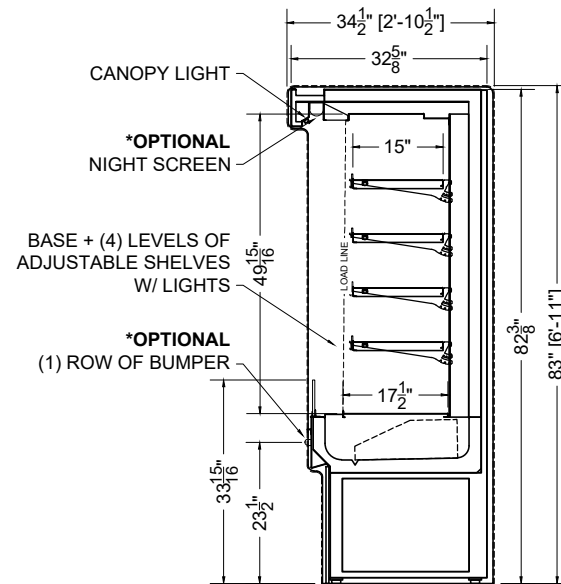

SECTION VIEW

PROJ SPECIFICATION SHEET

Des 12.0-MDC-83HN-R Narrow High Nose Multi-Deck

Name AME Dwg# 037854 Rev #01 - 11/14/23

CONFIDENTIAL DOCUMENT: THIS DRAWING IS CONFIDENTIAL AND THE PROPERTY OF SOUTHERN CASEARTS, INC AND IS NOT TO BE REPRODUCED OR EXCHANGED WITH ANY OTHER PERSON OR COMPANY WITHOUT THE EXPRESS WRITTEN CONSENT OF SOUTHERN CASEARTS, INC.

COPYRIGHT ©2023 SOUTHERN CASEARTS, INC. ALL RIGHTS RESERVED

38" = 1"

DRAWING DETAILS SUBJECT TO CHANGE DURING THE ENGINEERING PROCESS



SOUTHERN CaseArts