

12.3-SCS-49ASIR-R

CORONADO

QTY	DESCRIPTION	PART NUMBER	VOLTAGE	PHASE	AMPS	TOTAL AMPS
3	45" LED 2700K 24V	LG-FX-XXX-X	115V	1	0.50	1.50
4	EVAPORATOR FAN	AFXXX	115V	1	0.08	0.32
3	AIR SWEEP FAN	AFXXX	115V	1	0.08	0.24

CIRCUIT#1 (LIGHTS)	TOTAL AMPS: 1.50	VOLTAGE: 115/1/60	CONNECTION: HARDWIRED
CIRCUIT#2 (FANS)	TOTAL AMPS: 0.32	VOLTAGE: 115/1/60	CONNECTION: HARDWIRED
CIRCUIT#3 (ANTI-COND.)	TOTAL AMPS: 0.24	VOLTAGE: 115/1/60	CONNECTION: HARDWIRED
MODEL: SCS-49ASIR	APPLICATION: FRESH MEAT	BTUH: 7037	EVAP TEMP: 14°F
DEFROST: TIME-OFF, 4/45MIN, 50° TEMP TERMINATION			

PACKOUT VOLUME: 19.43 CUBIC FT.  
INTERNAL VOLUME: 52.29 CUBIC FT.  
REAR STORAGE: 13.12 CUBIC FT.

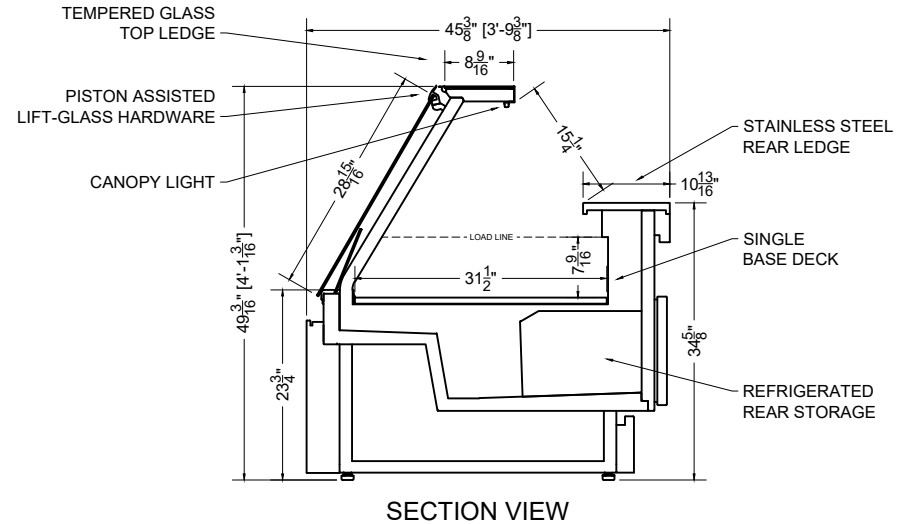

PROJ SPECIFICATION SHEET

Des 12.3-SCS-49ASIR-R Inclined Service Meat (W/ STORAGE)

Name AME Dwg# 038287 Rev #IR- 04/12/24

CONFIDENTIAL DOCUMENT: THIS DRAWING IS CONFIDENTIAL AND THE PROPERTY OF SOUTHERN CASEARTS, INC AND IS NOT TO BE REPRODUCED OR EXCHANGED WITH ANY OTHER PERSON OR COMPANY WITHOUT THE EXPRESS WRITTEN CONSENT OF SOUTHERN CASEARTS, INC.

COPYRIGHT ©2024 SOUTHERN CASEARTS, INC. ALL RIGHTS RESERVED

1/2" = 1'

DRAWING DETAILS SUBJECT TO CHANGE DURING THE ENGINEERING PROCESS



SOUTHERN  
CaseArts