

PLAN MECHANICAL VIEW

12.8-MDD-81TNF-R = 5 DOOR

DIABLO

QTY	DESCRIPTION	PART NUMBER	VOLTAGE	PHASE	AMPS	TOTAL AMPS
10	59" LED 4000K 24V	LG-FX-XXX-X	208-230V	1	0.67	6.67
5	EVAPORATOR FAN	AFXXX	208-230V	1	0.10	0.50
1	DOOR HEATERS	---	208-230V	1	2.91	2.91
1	DEFROST HEATERS	---	208-230V	1	22.77	22.77

CIRCUIT#1 (FANS & DOOR)	TOTAL AMPS: 3.41	VOLTAGE: 208-230/1/60	CONNECTION: HARDWIRED
CIRCUIT#2 (LIGHTS)	TOTAL AMPS: 6.67	VOLTAGE: 208-230/1/60	CONNECTION: HARDWIRED
CIRCUIT#3 (DEFROST HEATERS)		VOLTAGE: 208-230/1/60	CONNECTION: HARDWIRED
CIRCUIT#4 (DEFROST HEATERS)	TOTAL AMPS: 22.77	VOLTAGE: 208-230/1/60	CONNECTION: HARDWIRED
CIRCUIT#5 (DEFROST HEATERS)		VOLTAGE: 208-230/1/60	CONNECTION: HARDWIRED
MODEL: MDD-81TNF	APPLICATION: FROZEN	BTUH: 8727	EVAP TEMP: -31°F
DEFROST: TIME-OFF, 4/45MIN, 50° TEMP TERMINATION			

PACKOUT VOLUME: 134.17 CUBIC FT.
 INTERNAL VOLUME: 146.02 CUBIC FT.

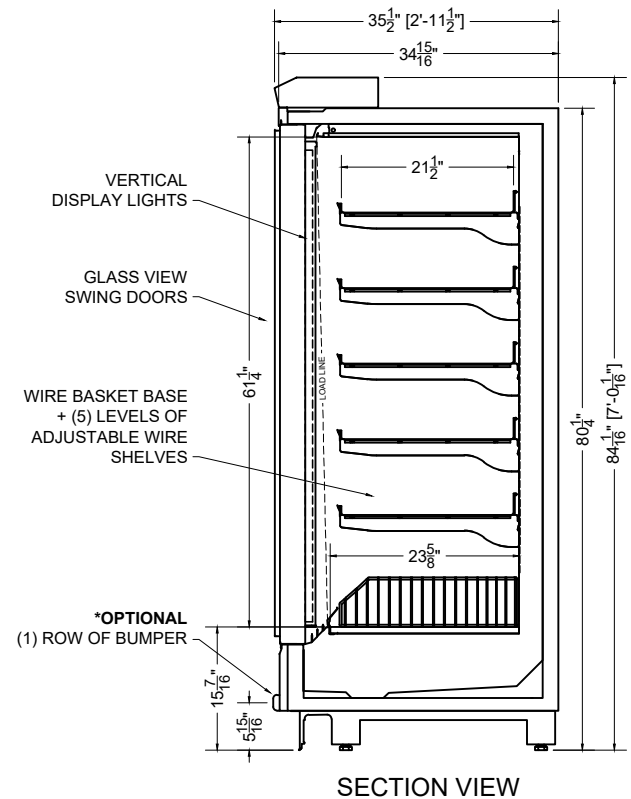

SECTION VIEW

PROJ SPECIFICATION SHEET

DESIGN 12.8-MDD-81TNF-R Glass Freezer Case (5 DOOR)

NAME AME DWG# 038126 REV #01-02/23/24

CONFIDENTIAL DOCUMENT: THIS DRAWING IS CONFIDENTIAL AND THE PROPERTY OF SOUTHERN CASEARTS, INC AND IS NOT TO BE REPRODUCED OR EXCHANGED WITH ANY OTHER PERSON OR COMPANY WITHOUT THE EXPRESS WRITTEN CONSENT OF SOUTHERN CASEARTS, INC.

COPYRIGHT ©2023 SOUTHERN CASEARTS, INC. ALL RIGHTS RESERVED

1/2" = 1'

DRAWING DETAILS SUBJECT TO CHANGE DURING THE ENGINEERING PROCESS



SOUTHERN CaseArts