

PLAN MECHANICAL VIEW

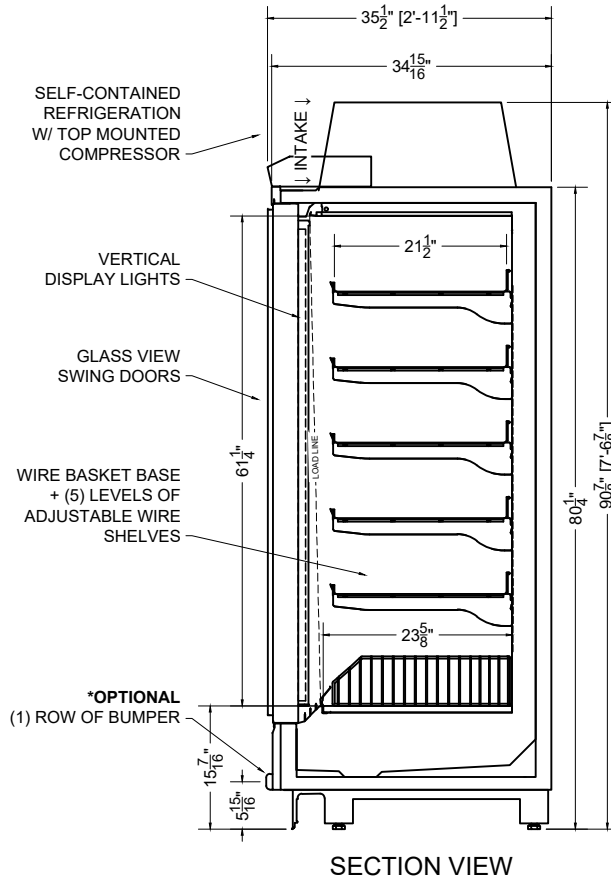

12.8-MDD-81TNF-S = SELF-CONTAINED, 5 DOOR

DIABLO

QTY	DESCRIPTION	PART NUMBER	VOLTAGE	PHASE	AMPS	TOTAL AMPS
10	59" LED 4000K 24V	LG-FX-XXX-X	208-230V	1	0.67	6.67
5	EVAPORATOR FAN	AFXXX	208-230V	1	0.10	0.50
1	DOOR HEATERS	---	208-230V	1	2.91	2.91
1	DEFROST HEATERS	---	208-230V	1	22.77	22.77
3	COMPRESSOR	---	208-230V	1	5.33	15.99
9	CONDENSER COIL FAN MOTOR	---	208-230V	1	0.10	0.90
1	CONDENSATE PUMP	---	208-230V	1	0.25	0.25
1	EVAP PAN	---	208-230V	1	1.82	1.82

*NOT INCLUDED IN TOTAL

CIRCUIT#1 TOTAL AMPS: 35.82" VOLTAGE: 208-230/1/60 CONNECTION: 6-50P
 * NOT ALL ELECTRICAL COMPONENTS RUN CONCURRENTLY (COMPRESSOR WILL NOT RUN DURING DEFROST)
 MODEL: MDD-81TNF APPLICATION: FROZEN BTUH: 8727 EVAP TEMP: -31°F
 DEFROST: TIME-OFF, 4/45MIN, 50° TEMP TERMINATION
 * R290 (PROPANE) REFRIGERATION AVAILABLE

PACKOUT VOLUME: 134.17 CUBIC FT.
 INTERNAL VOLUME: 146.02 CUBIC FT.

