



Diablo
Food Merchandiser | Frozen
MDD-81TNF



southerncasearts.com | 800.552.6283



OVERVIEW



The **Southern CaseArts Diablo** upright freezer is perfect for your frozen food section. It is available in multiple lengths with 2 to 5 doors sure to fit into your store layout. The **Diablo's** adjustable shelving provides easy customization to maximize product pack-out. Standard LED lighting and optional anti-fog glass doors provide customers with high visibility while reducing energy waste. Store associates will love the hassle-free maintenance and cleaning that comes from convenient lift-off panels that require no tools and a hinged fan shroud for effortless access. The **Diablo** is available as a remote or self-contained unit – both which are extremely energy efficient.

STANDARD FEATURES

- **Nominal Length:** 5.1', 7.7', 10.2' & 12.8'
- **Shelves:** 5 adjustable shelves
- **Shelf Capacity:** 275 lbs.
- **Doors:** Glass; Optional Anti-Fog Doors Available
- **Interior Lighting:** LED
- Remote and Self-Contained
- **Exterior:** Black powder coat

PRODUCT CATEGORIES



Frozen Food



Ice Cream

DOORS	LENGTH	HEIGHT* Incl./Excl. Top Pipe	DEPTH (To door handle)	DOOR HEIGHT	SHELF SIZE
2	61.5"	90.5"/87.6"	35.6"	64"	22"
3	92.5"	90.5"/87.6"	35.6"	64"	22"
4	123"	90.5"/87.6"	35.6"	64"	22"
5	153.75"	90.5"/87.6"	35.6"	64"	22"





05.1-MDD-81TNF-R = 2 DOOR | Diablo Upright Glass Door Freezer Case

QTY	DESCRIPTION	PART NUMBER	VOLTAGE	PHASE	AMPS	TOTAL AMPS
4	50" LED 4000K, 24V	LG-FX-XXX-X	208-230V	1	0.67	2.67
2	EVAPORATOR FAN	AFXXX	208-230V	1	0.10	0.20
1	DOOR HEATERS	---	208-230V	1	1.14	1.14
1	DEFROST HEATERS	---	208-230V	1	9.09	9.09

CIRCUIT#1 (FANS & DOOR) TOTAL AMPS: 1.34 VOLTAGE: 208-230/1/60 CONNECTION: HARDWIRED
 CIRCUIT#2 (LIGHTS) TOTAL AMPS: 2.67 VOLTAGE: 208-230/1/60 CONNECTION: HARDWIRED
 CIRCUIT#3 (DEFROST HEATERS) } TOTAL AMPS: 9.09 VOLTAGE: 208-230/1/60 CONNECTION: HARDWIRED
 CIRCUIT#4 (DEFROST HEATERS) } VOLTAGE: 208-230/1/60 CONNECTION: HARDWIRED
 CIRCUIT#5 (DEFROST HEATERS) } VOLTAGE: 208-230/1/60 CONNECTION: HARDWIRED
 MODEL: MDD-81TNF APPLICATION: FROZEN BTUH: 3491 EVAP TEMP: -31°F
 DEFROST: TIME-OFF, 4/45MIN, 50° TEMP TERMINATION PACKOUT VOLUME: 53.67 CUBIC FT.
 INTERNAL VOLUME: 58.41 CUBIC FT.

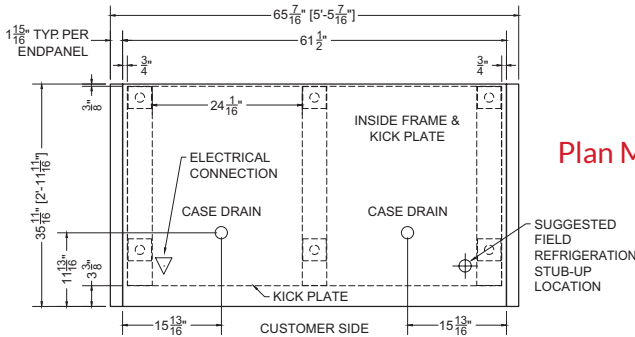

Plan Mechanical View

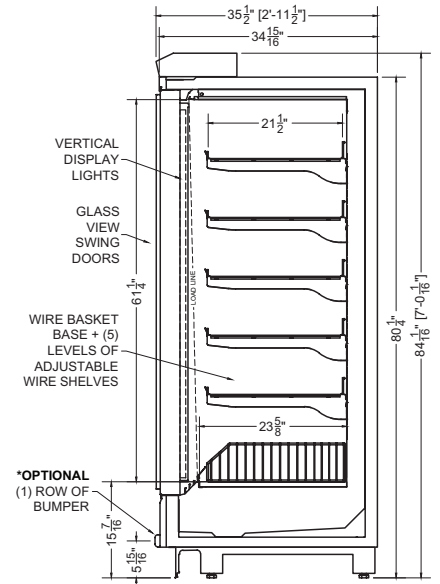

Section View

07.7-MDD-81TNF-R = 3 DOOR | Diablo Upright Glass Door Freezer Case

QTY	DESCRIPTION	PART NUMBER	VOLTAGE	PHASE	AMPS	TOTAL AMPS
4	59" LED 4000K, 24V	LG-FX-XXX-X	208-230V	1	0.67	4.00
2	EVAPORATOR FAN	AFXXX	208-230V	1	0.10	0.30
1	DOOR HEATERS	---	208-230V	1	1.73	1.73
1	DEFROST HEATERS	---	208-230V	1	13.64	13.64

CIRCUIT#1 (FANS & DOOR) TOTAL AMPS: 2.03 VOLTAGE: 208-230/1/60 CONNECTION: HARDWIRED
 CIRCUIT#2 (LIGHTS) TOTAL AMPS: 4.00 VOLTAGE: 208-230/1/60 CONNECTION: HARDWIRED
 CIRCUIT#3 (DEFROST HEATERS) } TOTAL AMPS: 13.64 VOLTAGE: 208-230/1/60 CONNECTION: HARDWIRED
 CIRCUIT#4 (DEFROST HEATERS) } VOLTAGE: 208-230/1/60 CONNECTION: HARDWIRED
 CIRCUIT#5 (DEFROST HEATERS) } VOLTAGE: 208-230/1/60 CONNECTION: HARDWIRED
 MODEL: MDD-81TNF APPLICATION: FROZEN BTUH: 5236 EVAP TEMP: -31°F
 DEFROST: TIME-OFF, 4/45MIN, 50° TEMP TERMINATION PACKOUT VOLUME: 80.50 CUBIC FT.
 INTERNAL VOLUME: 87.61 CUBIC FT.

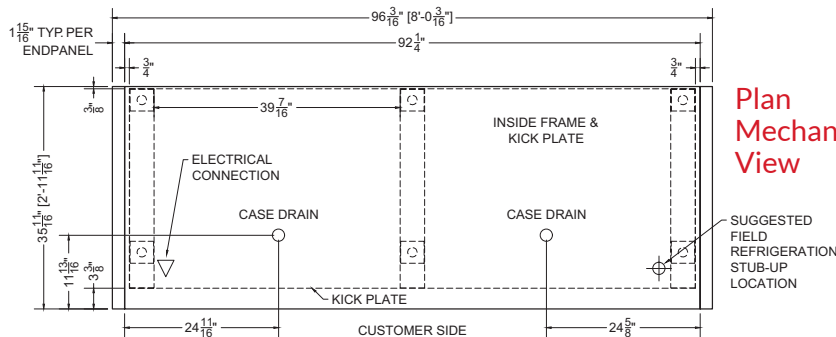

Plan Mechanical View

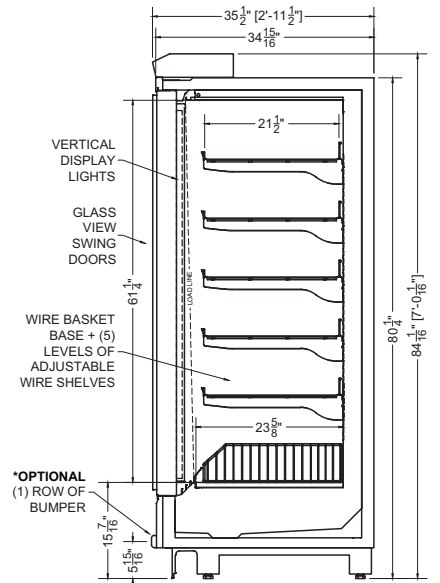

Section View



10.2-MDD-81TNF-R = 4 DOOR | Diablo Upright Glass Door Freezer Case

QTY	DESCRIPTION	PART NUMBER	VOLTAGE	PHASE	AMPS	TOTAL AMPS
8	59" LED 4000K, 24V	LG-FX-XXX-X	208-230V	1	0.67	5.33
4	EVAPORATOR FAN	AFXXX	208-230V	1	0.10	0.40
1	DOOR HEATERS	---	208-230V	1	2.27	2.27
1	DEFROST HEATERS	---	208-230V	1	18.18	18.18

CIRCUIT#1 (FANS & DOOR) TOTAL AMPS: 2.67
 CIRCUIT#2 (LIGHTS) TOTAL AMPS: 5.33
 CIRCUIT#3 (DEFROST HEATERS) } TOTAL AMPS: 18.18
 CIRCUIT#4 (DEFROST HEATERS) }
 CIRCUIT#5 (DEFROST HEATERS) }
 MODEL: MDD-81TNF APPLICATION: FROZEN BTUH: 6979
 DEFROST: TIME-OFF, 4/45MIN, 50° TEMP TERMINATION

VOLTAGE: 208-230/1/60 CONNECTION: HARDWIRED
 VOLTAGE: 208-230/1/60 CONNECTION: HARDWIRED
 VOLTAGE: 208-230/1/60 CONNECTION: HARDWIRED
 VOLTAGE: 208-230/1/60 CONNECTION: HARDWIRED
 EVAP TEMP: -31°F
 PACKOUT VOLUME: 107.34 CUBIC FT.
 INTERNAL VOLUME: 116.82 CUBIC FT.

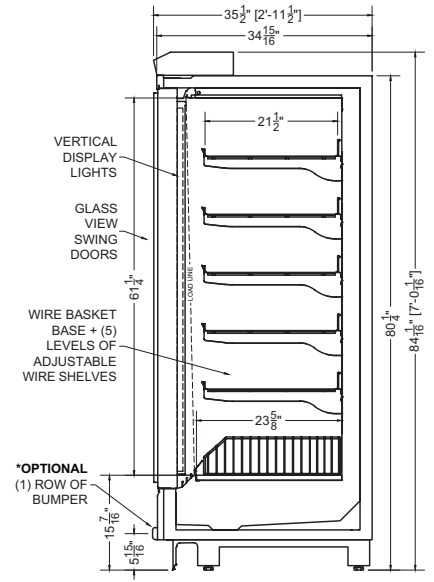

Section View

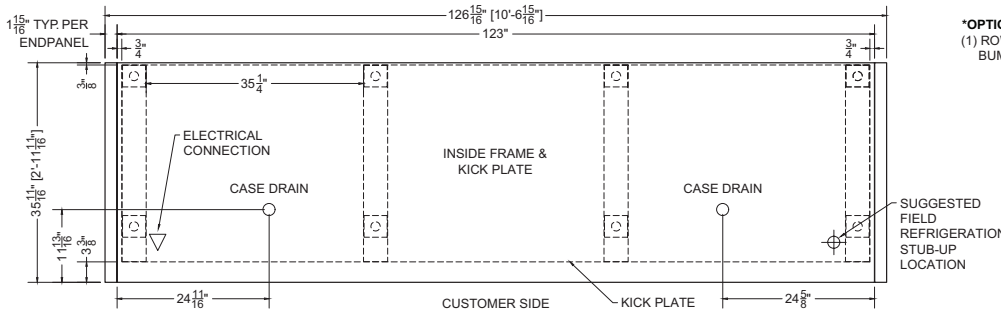

Plan Mechanical View

12.8-MDD-81TNF-R = 5 DOOR | Diablo Upright Glass Door Freezer Case

QTY	DESCRIPTION	PART NUMBER	VOLTAGE	PHASE	AMPS	TOTAL AMPS
10	59" LED 4000K, 24V	LG-FX-XXX-X	208-230V	1	0.67	6.67
5	EVAPORATOR FAN	AFXXX	208-230V	1	0.10	0.50
1	DOOR HEATERS	---	208-230V	1	2.91	2.91
1	DEFROST HEATERS	---	208-230V	1	22.77	22.77

CIRCUIT#1 (FANS & DOOR) TOTAL AMPS: 3.41
 CIRCUIT#2 (LIGHTS) TOTAL AMPS: 6.67
 CIRCUIT#3 (DEFROST HEATERS) } TOTAL AMPS: 22.77
 CIRCUIT#4 (DEFROST HEATERS) }
 CIRCUIT#5 (DEFROST HEATERS) }
 MODEL: MDD-81TNF APPLICATION: FROZEN BTUH: 8727
 DEFROST: TIME-OFF, 4/45MIN, 50° TEMP TERMINATION

VOLTAGE: 208-230/1/60 CONNECTION: HARDWIRED
 VOLTAGE: 208-230/1/60 CONNECTION: HARDWIRED
 VOLTAGE: 208-230/1/60 CONNECTION: HARDWIRED
 VOLTAGE: 208-230/1/60 CONNECTION: HARDWIRED
 EVAP TEMP: -31°F
 PACKOUT VOLUME: 134.17 CUBIC FT.
 INTERNAL VOLUME: 146.02 CUBIC FT.

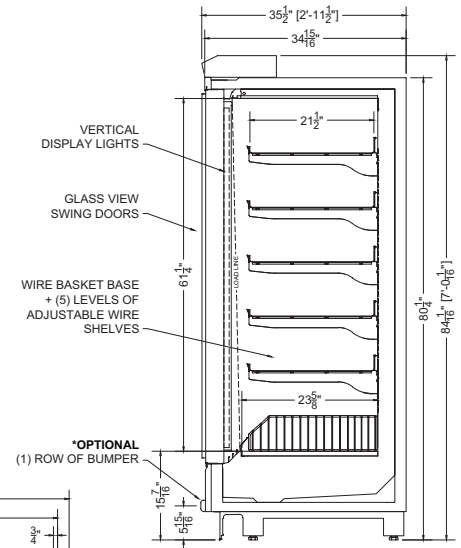

Section View

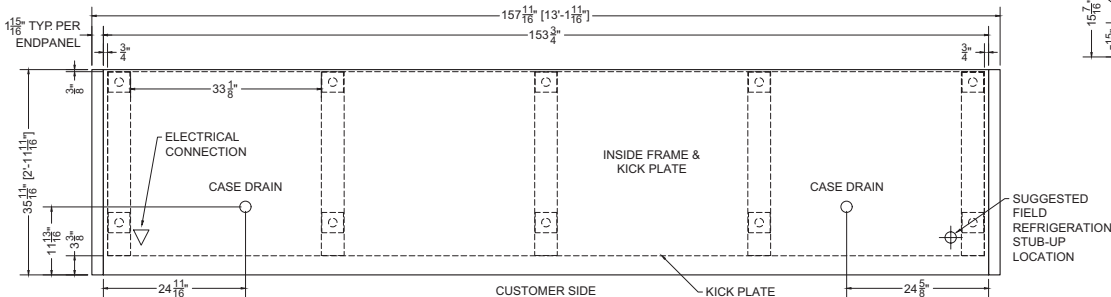

Plan Mechanical View



05.1-MDD-81TNF-S = 2 DOOR | Diablo Upright Glass Door Freezer Case

QTY	DESCRIPTION	PART NUMBER	VOLTAGE	PHASE	AMPS	TOTAL AMPS
4	50" LED 4000K, 24V	LG-FX-XXX-X	208-230V	1	0.67	2.67
2	EVAPORATOR FAN	AFXXX	208-230V	1	0.10	0.20
1	DOOR HEATERS	---	208-230V	1	1.14	1.14
1	DEFROST HEATERS	---	208-230V	1	9.09	9.09
1	COMPRESSOR	---	208-230V	1	6.17	6.17
3	CONDENSER COIL FAN MOTOR	---	208-230V	1	0.10	0.10
1	CONDENSATE PUMP	---	208-230V	1	0.25	0.25
1	EVAP PAN	---	208-230V	1	1.82	1.82

CIRCUIT#1 (FANS & DOOR) **TOTAL AMPS: 15.46*** **VOLTAGE: 208-230/1/60** **CONNECTION: 6-30P**
 * NOT ALL ELECTRICAL COMPONENTS RUN CONCURRENTLY (COMPRESSOR WILL NOT RUN DURING DEFROST)
MODEL: MDD-81TNF **APPLICATION: FROZEN** **BTUH: 3491** **EVAP TEMP: -31°F**
DEFROST: TIME-OFF, 4/45MIN, 50° TEMP TERMINATION **PACKOUT VOLUME: 53.67 CUBIC FT.**
*** R290 (PROPANE) REFRIGERATION AVAILABLE** **INTERNAL VOLUME: 58.41 CUBIC FT.**
 *NOT INCLUDED IN TOTAL

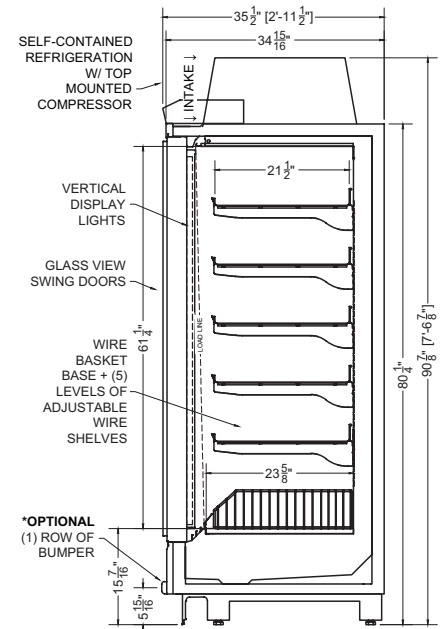
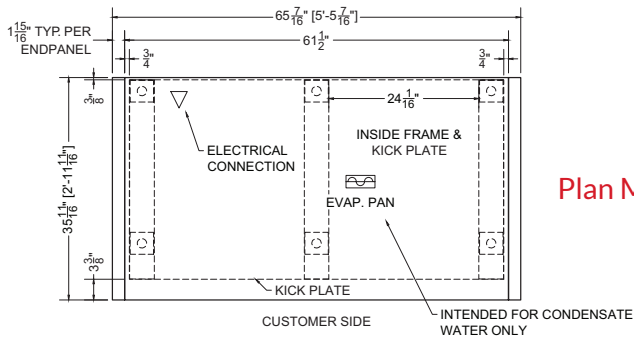

07.7-MDD-81TNF-S = 3 DOOR | Diablo Upright Glass Door Freezer Case

QTY	DESCRIPTION	PART NUMBER	VOLTAGE	PHASE	AMPS	TOTAL AMPS
6	59" LED 4000K, 24V	LG-FX-XXX-X	208-230V	1	0.67	4.00
3	EVAPORATOR FAN	AFXXX	208-230V	1	0.10	0.30
1	DOOR HEATERS	---	208-230V	1	1.73	1.73
1	DEFROST HEATERS	---	208-230V	1	13.64	13.64
2	COMPRESSOR	---	208-230V	1	5.32	10.64
6	CONDENSER COIL FAN MOTOR	---	208-230V	1	0.10	0.60
1	CONDENSATE PUMP	---	208-230V	1	0.25	0.25
1	EVAP PAN	---	208-230V	1	1.82	1.82

CIRCUIT#1 (FANS & DOOR) **TOTAL AMPS: 22.35*** **VOLTAGE: 208-230/1/60** **CONNECTION: 6-50P**
 * NOT ALL ELECTRICAL COMPONENTS RUN CONCURRENTLY (COMPRESSOR WILL NOT RUN DURING DEFROST)
MODEL: MDD-81TNF **APPLICATION: FROZEN** **BTUH: 5236** **EVAP TEMP: -31°F**
DEFROST: TIME-OFF, 4/45MIN, 50° TEMP TERMINATION **PACKOUT VOLUME: 80.50 CUBIC FT.**
*** R290 (PROPANE) REFRIGERATION AVAILABLE** **INTERNAL VOLUME: 87.61 CUBIC FT.**
 *NOT INCLUDED IN TOTAL

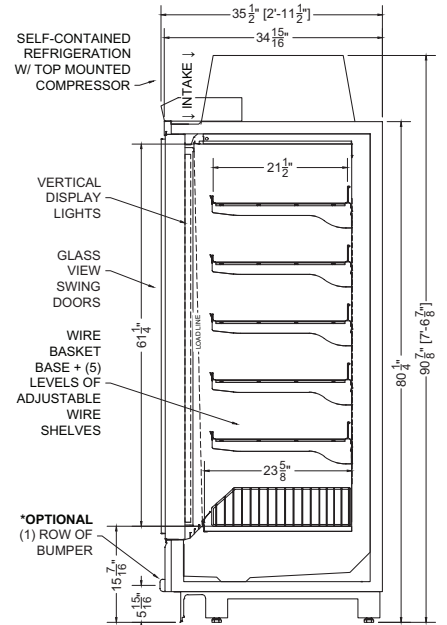
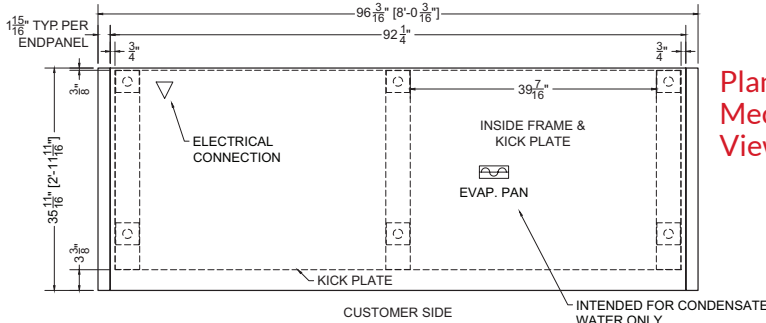



10.2-MDD-81TNF-S = 4 DOOR | Diablo Upright Glass Door Freezer Case

QTY	DESCRIPTION	PART NUMBER	VOLTAGE	PHASE	AMPS	TOTAL AMPS
8	59" LED 4000K, 24V	LG-FX-XXX-X	208-230V	1	0.67	5.33
4	EVAPORATOR FAN	AFXXX	208-230V	1	0.10	0.40
1	DOOR HEATERS	---	208-230V	1	2.27	2.27
1	DEFROST HEATERS	---	208-230V	1	18.18	18.18
2	COMPRESSOR	---	208-230V	1	6.17	12.34
6	CONDENSER COIL FAN MOTOR	---	208-230V	1	0.10	0.60
1	CONDENSATE PUMP	---	208-230V	1	0.25	0.25
1	EVAP PAN	---	208-230V	1	1.82	1.82

CIRCUIT#1 (FANS & DOOR) **TOTAL AMPS: 28.85*** **VOLTAGE: 208-230/1/60** **CONNECTION: 6-50P**
 *NOT ALL ELECTRICAL COMPONENTS RUN CONCURRENTLY (COMPRESSOR WILL NOT RUN DURING DEFROST)
 MODEL: MDD-81TNF **APPLICATION: FROZEN** **BTUH: 6892** **EVAP TEMP: -31°F**
DEFROST: TIME-OFF, 4/45MIN, 50° TEMP TERMINATION **PACKOUT VOLUME: 107.34 CUBIC FT.**
***R290 (PROPANE) REFRIGERATION AVAILABLE** **INTERNAL VOLUME: 116.82 CUBIC FT.**
***NOT INCLUDED IN TOTAL**

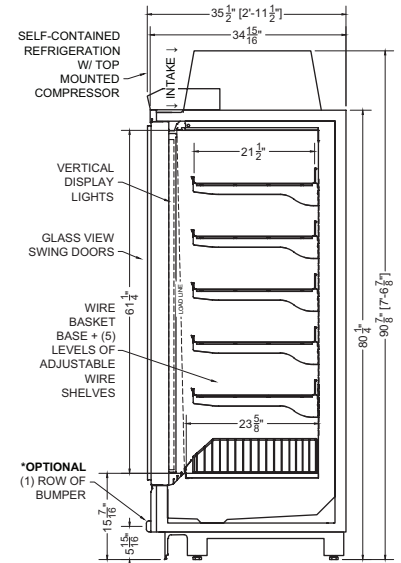

Section View

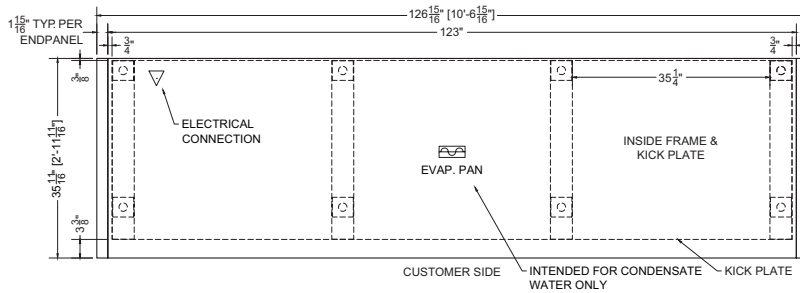

Plan Mechanical View

12.8-MDD-81TNF-S = 5 DOOR | Diablo Upright Glass Door Freezer Case

QTY	DESCRIPTION	PART NUMBER	VOLTAGE	PHASE	AMPS	TOTAL AMPS
10	59" LED 4000K, 24V	LG-FX-XXX-X	208-230V	1	0.67	6.67
5	EVAPORATOR FAN	AFXXX	208-230V	1	0.10	0.50
1	DOOR HEATERS	---	208-230V	1	2.91	2.91
1	DEFROST HEATERS	---	208-230V	1	22.77	22.77
3	COMPRESSOR	---	208-230V	1	5.33	15.99
9	CONDENSER COIL FAN MOTOR	---	208-230V	1	0.10	0.90
1	CONDENSATE PUMP	---	208-230V	1	0.25	0.25
1	EVAP PAN	---	208-230V	1	1.82	1.82

CIRCUIT#1 (FANS & DOOR) **TOTAL AMPS: 35.82*** **VOLTAGE: 208-230/1/60** **CONNECTION: 6-50P**
 *NOT ALL ELECTRICAL COMPONENTS RUN CONCURRENTLY (COMPRESSOR WILL NOT RUN DURING DEFROST)
 MODEL: MDD-81TNF **APPLICATION: FROZEN** **BTUH: 8727** **EVAP TEMP: -31°F**
DEFROST: TIME-OFF, 4/45MIN, 50° TEMP TERMINATION **PACKOUT VOLUME: 134.17 CUBIC FT.**
***R290 (PROPANE) REFRIGERATION AVAILABLE** **INTERNAL VOLUME: 146.02 CUBIC FT.**
***NOT INCLUDED IN TOTAL**

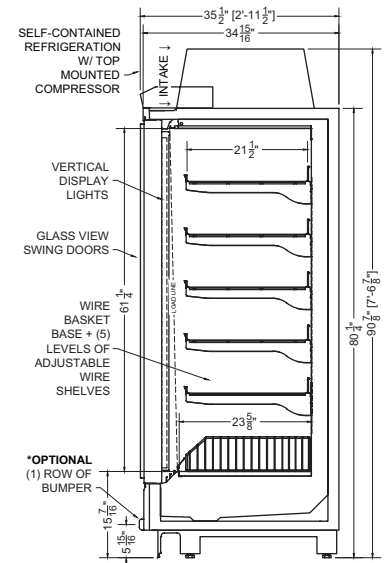

Section View

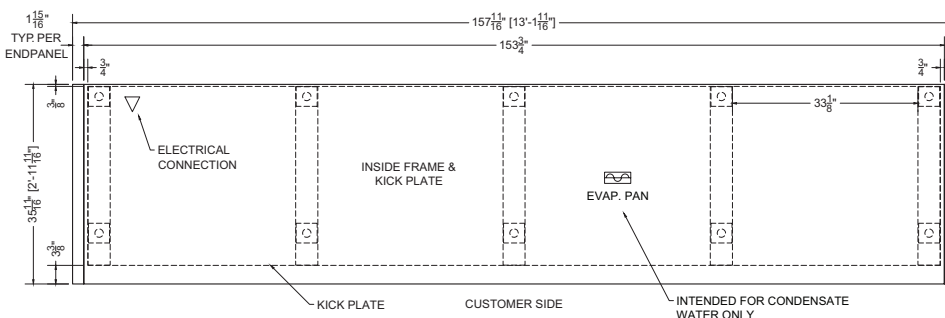

Plan Mechanical View

For more information on this Diablo Upright Glass Door Freezer Case, contact one of our Southern CaseArts representatives or check out our website to learn more about all of the products offered by Southern CaseArts.