



Shenandoah
Bakery Service Merchandiser | Cold
BCX-S-R



southerncasearts.com | 800.552.6283



OVERVIEW



The **Shenandoah Bakery Service Merchandiser** from **Southern CaseArts** is an ideal service case for your store. Available in three length options. The reflective sliding service doors and adjustable glass shelves with LED lighting will draw customers to meat, deli items, cheese and bakery. The energy efficient **Shenandoah** is sure to become a favorite customer destination for years to come.

STANDARD FEATURES

- **Nominal Length:** 6.0', 8.0' & 12.0'
- **Interior Lighting:** 3500K LED lights
- **Shelving:** 3 adjustable glass shelves with LED lights
- Remote
- **Exterior:** Glass and black powder coat

PRODUCT CATEGORIES



Meat



Deli



Cheese/
Dairy



Bakery

06.0-BCX-S-R | Shenandoah Bakery Service Merchandiser

QTY	DESCRIPTION	PART NUMBER	VOLTAGE	PHASE	AMPS	TOTAL AMPS
10	34" LED 3500K, FROSTED, 24V	LG-FX-XXX-X	115V	1	0.07	0.70
3	EVAPORATOR FAN	RF-FA-XXXX	115V	1	0.17	0.51
2	AIR SWEEP FAN	AFXXX	115V	1	0.24	0.48

CIRCUIT#1 (LIGHTS) **TOTAL AMPS: 0.70** **VOLTAGE: 115/1/60** **CONNECTION: HARDWIRED**
 CIRCUIT#2 (FANS) **TOTAL AMPS: 0.99** **VOLTAGE: 115/1/60** **CONNECTION: HARDWIRED**
 CIRCUIT#3 (CONV. OUTLET) **TOTAL AMPS: 20.00** **VOLTAGE: 115/1/60** **CONNECTION: HARDWIRED**
MODEL: BCX-S **APPLICATION: BAKERY/PASTRY** **BTUH: 4800** **EVAP TEMP: 24°F**
DEFROST: TIME-OFF, 4/30MIN, 47° TEMP TERMINATION
SHIPPING DIMENSIONS: 86" X 48" X 62" **PACKOUT VOLUME: 25.65 CUBIC FT.**
WEIGHT: 1030 LBS **INTERNAL VOLUME: 35.58 CUBIC FT.**



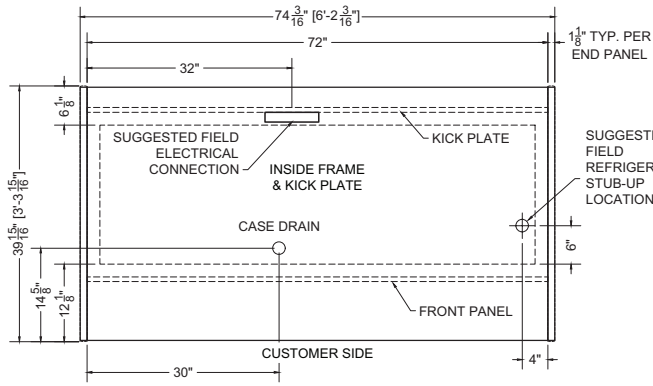

Plan Mechanical View

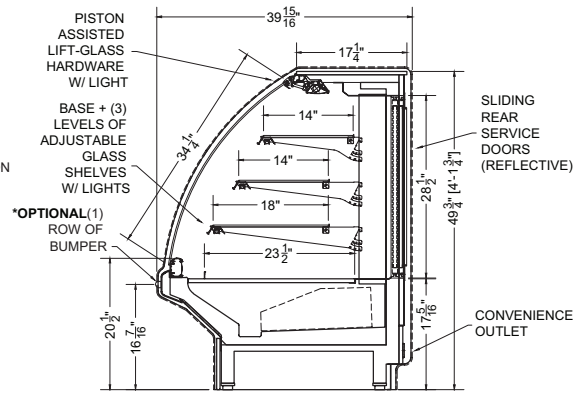

Section View

08.0-BCX-S-R | Shenandoah Bakery Service Merchandiser

QTY	DESCRIPTION	PART NUMBER	VOLTAGE	PHASE	AMPS	TOTAL AMPS
10	45" LED 3500K, FROSTED, 24V	LG-FX-XXX-X	115V	1	0.09	0.90
4	EVAPORATOR FAN	RF-FA-XXXX	115V	1	0.17	0.68
3	AIR SWEEP FAN	AFXXX	115V	1	0.24	0.72

CIRCUIT#1 (LIGHTS) **TOTAL AMPS: 0.90** **VOLTAGE: 115/1/60** **CONNECTION: HARDWIRED**
 CIRCUIT#2 (FANS) **TOTAL AMPS: 1.40** **VOLTAGE: 115/1/60** **CONNECTION: HARDWIRED**
 CIRCUIT#3 (CONV. OUTLET) **TOTAL AMPS: 20.00** **VOLTAGE: 115/1/60** **CONNECTION: HARDWIRED**
 MODEL: BCX-S **APPLICATION: BAKERY/PASTRY** **BTUH: 6400** **EVAP TEMP: 24°F**
DEFROST: TIME-OFF, 4/30MIN, 47° TEMP TERMINATION
SHIPPING DIMENSIONS: 107" X 48" X 62" **PACKOUT VOLUME: 34.20 CUBIC FT.**
WEIGHT: 1313 LBS **INTERNAL VOLUME: 47.44 CUBIC FT.**
 * OPTIONAL COMPONENT LOAD INCLUDED

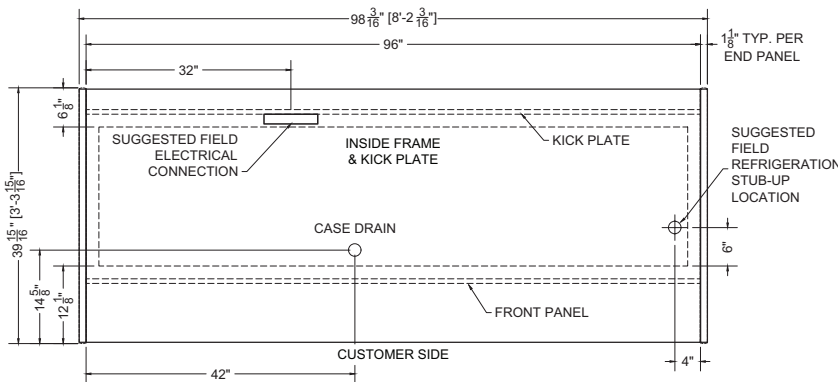

Plan Mechanical View

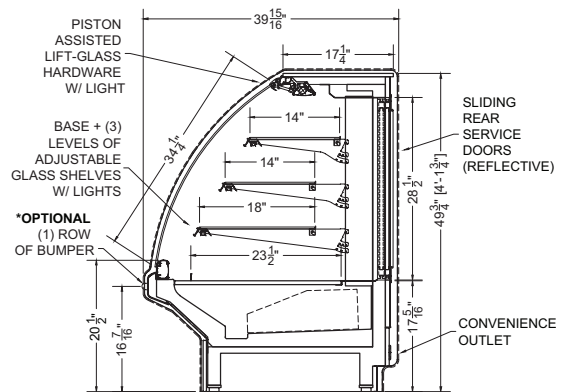

Section View



12.0-BCX-S-R | Shenandoah Bakery Service Merchandiser

QTY	DESCRIPTION	PART NUMBER	VOLTAGE	PHASE	AMPS	TOTAL AMPS
15	45" LED 3500K, FROSTED, 24V	LG-FX-XXX-X	115V	1	0.09	1.35
6	EVAPORATOR FAN	RF-FA-XXXX	115V	1	0.17	1.02
5	AIR SWEEP FAN	AFXXX	115V	1	0.24	1.20

CIRCUIT#1 (LIGHTS) **TOTAL AMPS: 1.35** **VOLTAGE: 115/1/60** **CONNECTION: HARDWIRED**
 CIRCUIT#2 (FANS) **TOTAL AMPS: 2.22** **VOLTAGE: 115/1/60** **CONNECTION: HARDWIRED**
 CIRCUIT#3 (CONV. OUTLET) **TOTAL AMPS: 20.00** **VOLTAGE: 115/1/60** **CONNECTION: HARDWIRED**
MODEL: BCX-S **APPLICATION: BAKERY/PASTRY** **BTUH: 9600** **EVAP TEMP: 24°F**
DEFROST: TIME-OFF, 4/30MIN, 47° TEMP TERMINATION
SHIPPING DIMENSIONS: 160" X 48" X 62" **PACKOUT VOLUME: 51.30 CUBIC FT.**
WEIGHT: 1939 LBS **INTERNAL VOLUME: 71.15 CUBIC FT.**
 * OPTIONAL COMPONENT LOAD INCLUDED

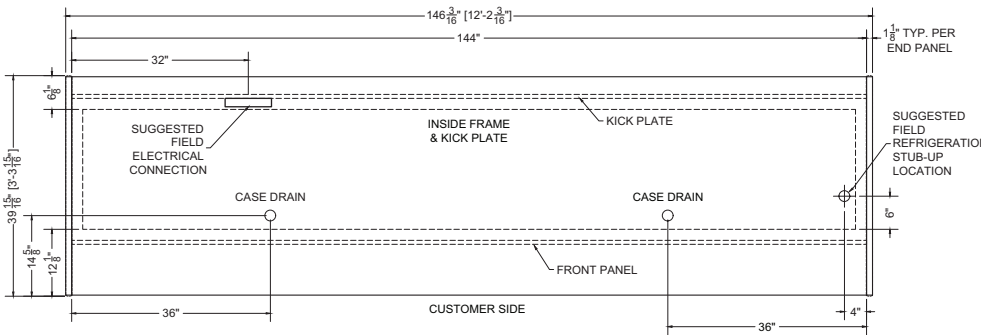

Plan Mechanical View

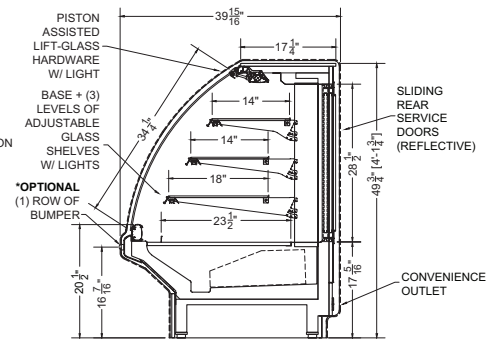

Section View



CONFORMS TO UL STD 471.
 CONFORMS TO NSF STD 7.
 CERTIFIED TO CAN/CSA STD C22.2 NO. 120.

For more information on the Shenandoah Bakery Service Merchandiser, contact one of our **Southern CaseArts** representatives or check out our website to learn more about all of the products offered by **Southern CaseArts**.



southerncasearts.com

© 2024 Southern CaseArts. All rights reserved. Information and specifications subject to change without notice. All values are design or typical values when measured under laboratory conditions.